

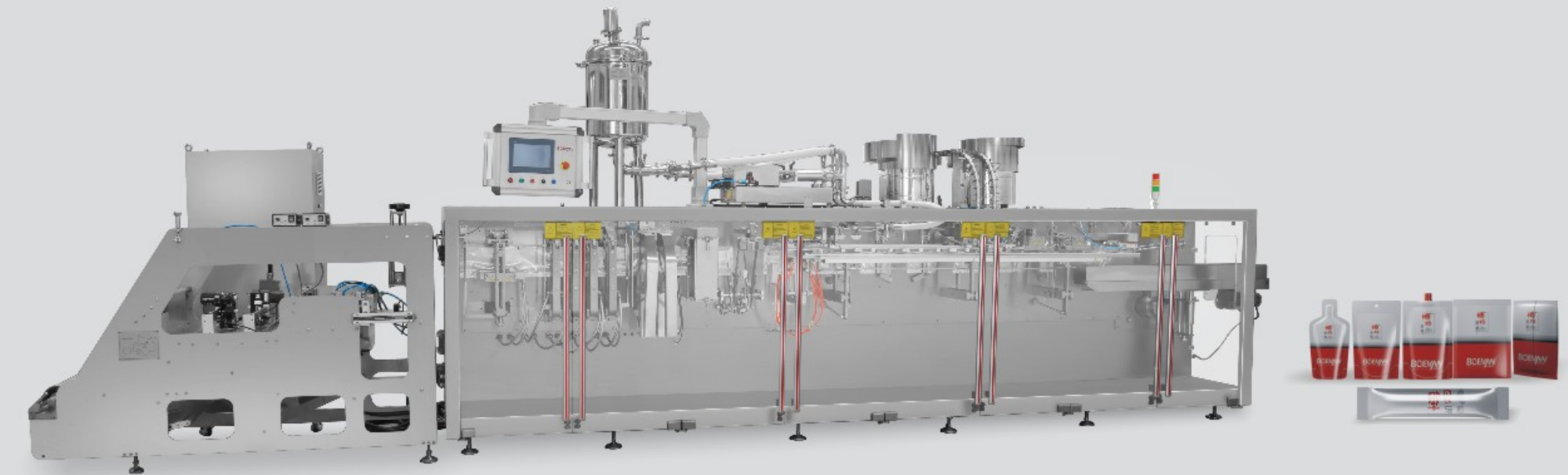

上海博灼包装机械有限公司
Shanghai Boevan Packaging Machinery Co., Ltd

地址：上海市奉贤区南桥镇金轩路1688号
电话：86-21-3468 9559
传真：86-21-5749 2605
网址：www.boevan.com
邮箱：info@boevan.cn
Add: No. 1688, Jinxuan Road, Nanqiao Town, Fengxian District, Shanghai (201416), P.R. China
Tel: 86-21-3468 9559
Fax: 86-21-5749 2605
Web: www.boevan.com
E-mail: info@boevan.cn



上海博灼包装机械有限公司
Shanghai Boevan Packaging Machinery Co., Ltd

金卓广告策划有限公司 18005875567

What makes your package
是什么让您的包装
与众不同 **Unique ?**



博灼—包装机械领先企业

LEADING
PACKAGING
MACHINERY

www.boevan.com

CHAIRMAN'S SPEECH

董事长致辞

卓越于芯，
精致以形
Excellent in Core
Exquisite in Shape



www.boevan.com



为员工提供创造财富和幸福生活的平台；尊重每一位员工，坚持人才是公司第一财富的理念；以业绩为导向，通过公平、公正的竞争，帮助员工实现自我价值；以人性化的企业管理、良好的企业文化形态，营造充满和谐友爱的工作氛围。

Provide a platform for employees to create wealth and happy life; respect every employee, adhere to the concept that talent is the company's first wealth; performance-oriented, through fair and just competition, help employees achieve self-worth; humanized enterprise management, good corporate culture, create a harmonious and friendly working atmosphere.

——徐廷涛

ABOUT US

关于博灼



工厂视频
Factory video



www.boevan.com



上海博灼包装机械有限公司,成立于2012年,厂房面积10余亩,拥有专业的技术团队和严格的质量控制体系,为全球性的包装系统供应商。一家专门从事软袋全自动包装机械的设计、制造、销售与服务的现代化型企业,产品广泛应用于食品、化工、制药、日用化学品、健康产品等的全自动包装生产线,并已远销海外30多个国家和地区。

公司以满足客户多样化包装需求为市场导向,依托公司先进的设计理念和丰富的包装经验,无论是粉末、颗粒、液体、粘稠液体、块、棒等,均能提供完美的包装解决方案,为客户创造包装价值。

严格的质量控制、专业的技术支持,高效的售后服务,博灼的每一步旨在降低您的成本,提高您的生产力和竞争力。

Shanghai Boevan Packaging Machinery Co., Ltd., established in 2012 and occupied 6,500m², is a dynamic global packaging group, with professional technical teams and strict quality control. No matter for powder, granule, liquid, viscous liquid, block, stick, etc., perfect packaging solution can be offered here according to your product characteristics.

Boevan is dedicated to designing, manufacturing and services for automatic horizontal packaging machinery and automatic filling machinery. Market-orientedness demands on diversity of packaging products and their services.

Each step of Boevan – strict quality control, professional technical support, efficient after-sales service, aims to reduce your cost, boost your productivity and enhance your competitiveness.



HONOR QUALIFICATION

荣誉资质

www.boevan.com



诚信构建和谐，诚信取得荣誉

Honesty Builds Harmony,
Honesty Gains Honor

05 Web: www.boevan.com

一份耕耘，一份收获。
我们一次次地播撒希望，我们一次次地收获喜悦。
所有的荣誉无不凝聚着全体员工的智慧和奉献，无不浸透着各级领导和社会各界的关心与支持。我们知道所有的荣誉只能代表过去，我们要走的路还很漫长。我们绝不驻足停留，更不能居功自傲，我们还将躬身跋涉，因为我们的目光已看得更远。

A plough, a harvest.
We sow hope time after time, and we reap joy time after time.
All the honors are condensing the wisdom and dedication of all staff, and are permeated with the concern and support of leaders at all levels and all walks of life. We know that all honors can only represent the past. We still have a long way to go. We will never stop, let alone be proud of and we will go all the way, because our eyes have seen farther.



OUR TEAM

www.boevan.com



我们的团队

Building talent teams at different business levels and professional fields
打造不同业务层次和专业领域的人才团队



能用众力，则无敌于天下；能用众智，则无畏于圣人。公司始终坚持“以人为本”的团队协作理念，拥有一支具有专业技术、专业管理的经验团队，具有非凡的执行力和团结的凝聚力，本着精益求精的工作态度，竭诚为用户提供满意的服务。



If you can use all your strength, you will be invincible in the world; if you can use all your wisdom, you will not be afraid of saints. The company has always adhered to the "people-oriented" team cooperation concept, has a professional technology, professional management experience team, with extraordinary execution and unity of cohesion, in line with the work attitude of excellence, dedicated to provide users with satisfactory service.



PRODUCTION WORKSHOP

生产车间



Strict on-site management of the workshop, the implementation of 6S set-up regulations, compliance with various operating procedures, safe production, has become the driving force for the development of enterprises. Continuously strengthen the research and development and innovation of core technology, constantly strive for excellence and excellence, with advanced production equipment, strict quality management, precision production testing process, to ensure the excellent performance of each product.



09 Web:www.boevan.com

www.boevan.com



严格的车间现场管理，实行6s定置规定，遵守各项操作规程，安全生产，成为企业的发展动力。不断加强核心技术的研发和创新，不断追求卓越，精益求精，以先进的生产设备，严格的质量管理，精密的生产检测流程，保证每一款产品的优良性能。

以专业引领科技，
以科技成就专业

Leading science and technology with specialty and
achieving specialty with science and technology



E-mail: info@boevan.cn 10

COOPERATIVE PARTNER

合作伙伴

www.boevan.com



融合现代理念，接轨国际大市场
Integration of modern concept
Integration with international market



PRODUCT CATALOG

产品目录

| | | |
|-------|--|-----------|
| 15-16 | 水平卷膜异形自立袋包装机 BHD-130S/240DS Horizontal Shape Doypack Bag Packager | ①-⑤ |
| 17-18 | 水平包装机 BHD-180S/SZ/SC Horizontal Form Fill Seal Packing Machine | ①-⑩ |
| 19-20 | 水平包装机 BHD-240S/SZ/SC Horizontal Form Fill Seal Packing Machine | ①-⑩ |
| 21-22 | 水平包装机 BHD-280DS/DSZ/DSC Horizontal Form Fill Seal Packing Machine | ①-⑩ |
| 23-24 | 水平包装机 BHP-200 Horizontal Premade Fill Seal Packing Machine | ③-⑥ ⑪-⑬ |
| 25-26 | 水平包装机 BHP-210/Z、240/Z Horizontal Premade Fill Seal Packing Machine | ①-⑦ ⑪-⑬ ⑮ |
| 27-28 | 水平包装机 BHP-210D/280D/280DZ Horizontal Premade Fill Seal Packing Machine | ①-⑦ ⑪-⑬ ⑮ |
| 29-30 | 旋转给袋机 BRS-4S Rotary Pouch Fill Seal Packing Machine | ⑧-⑩ |
| 31-32 | 水平包装机 BHS-110/130 Horizontal Form Fill Seal Sachet Bag Packing Machine | ⑪-⑫ |
| 33-34 | 水平包装机 BHS-180/180T Horizontal Form Fill Seal Sachet Bag Packing Machine | ⑪-⑮ |
| 35-36 | 水平包装机 BHS-210D/240D Horizontal Form Fill Seal Sachet Bag Packing Machine | ⑪-⑬ ⑮ |
| 37-38 | 立式条包单列机 Vertical Single Lane Stick Bag Packing Machine | ⑳-㉔ |
| 39-40 | 粉体条状包多列包装机 Multilane Stick Bag Packing Machine For Powder | ⑳-㉔ |
| 41-42 | 颗粒条状包多列包装机 Multilane Stick Bag Packing Machine For Granule | ⑳-㉔ |
| 43-44 | 液体条状包多列包装机 Multilane Stick Bag Packing Machine For Liquid | ⑳-㉔ |
| 45-46 | 全自动四边封多列包装机 Automatic Multilanes Four Side Seal Bag Packing Machine | ⑫ |
| 47-48 | 立式包装机 BVL-420/520/620/720 Vertical Form Fill Seal Pillow Bag Packing Machine | ⑮ |
| 49-50 | 立式包装机 BVL-520Q Vertical Form Fill Seal Gusset Pillow Bag Packing Machine | ⑰-⑳ |
| 51-52 | 全自动装盒机械 BCP-120G/K Automatic Cartoner | |
| 53-54 | 全自动装盒装箱整线方案 Full Automatic Packing Line Solution | |
| 55-58 | 下料装置 Filling Devices | |
| 59 | 上料装置 Feeding Devices | |

样袋 POUCH

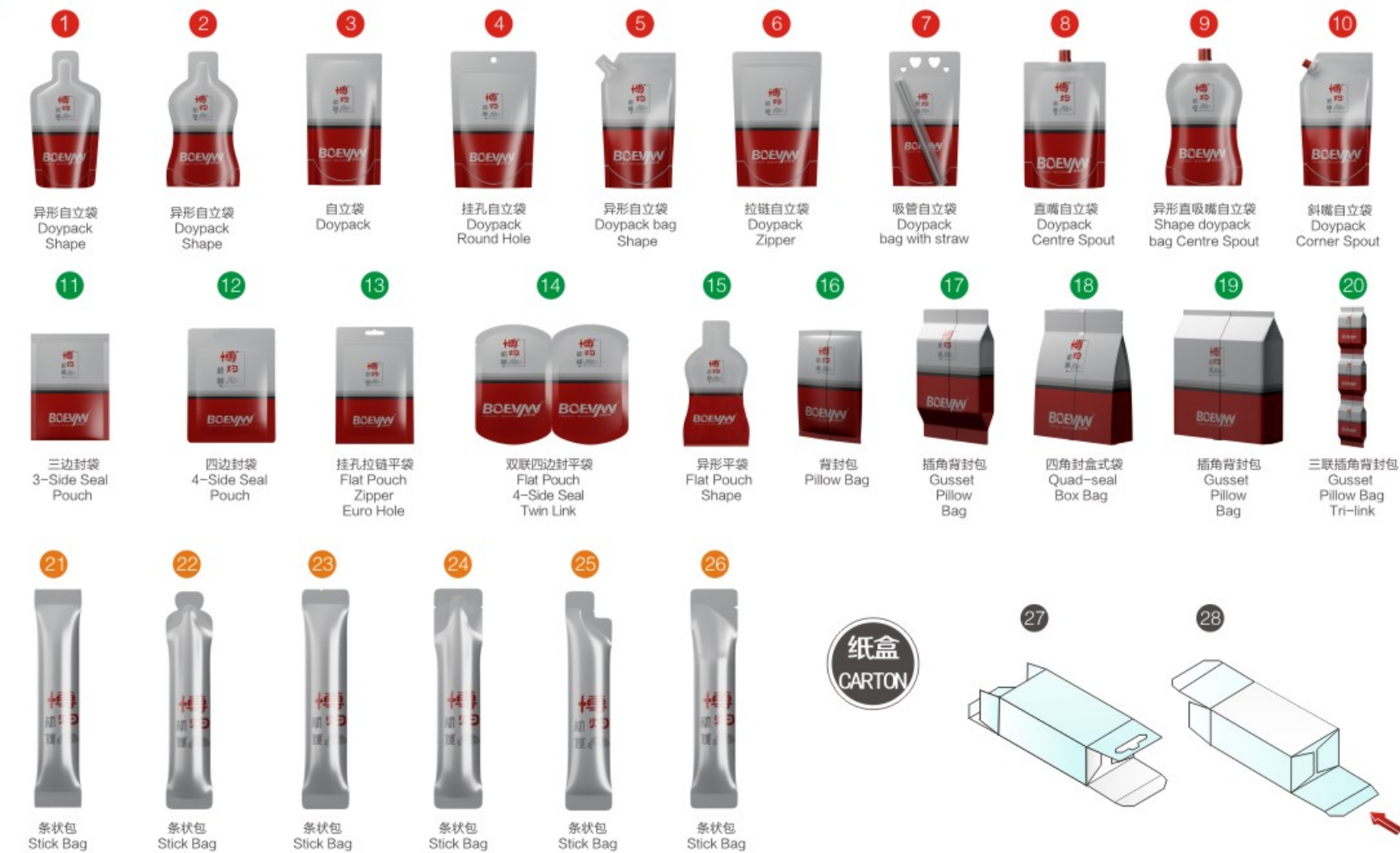

水平卷膜异型自立袋包装机 Horizontal Shape Doypack Bag Packager

BHD-130S/240DS

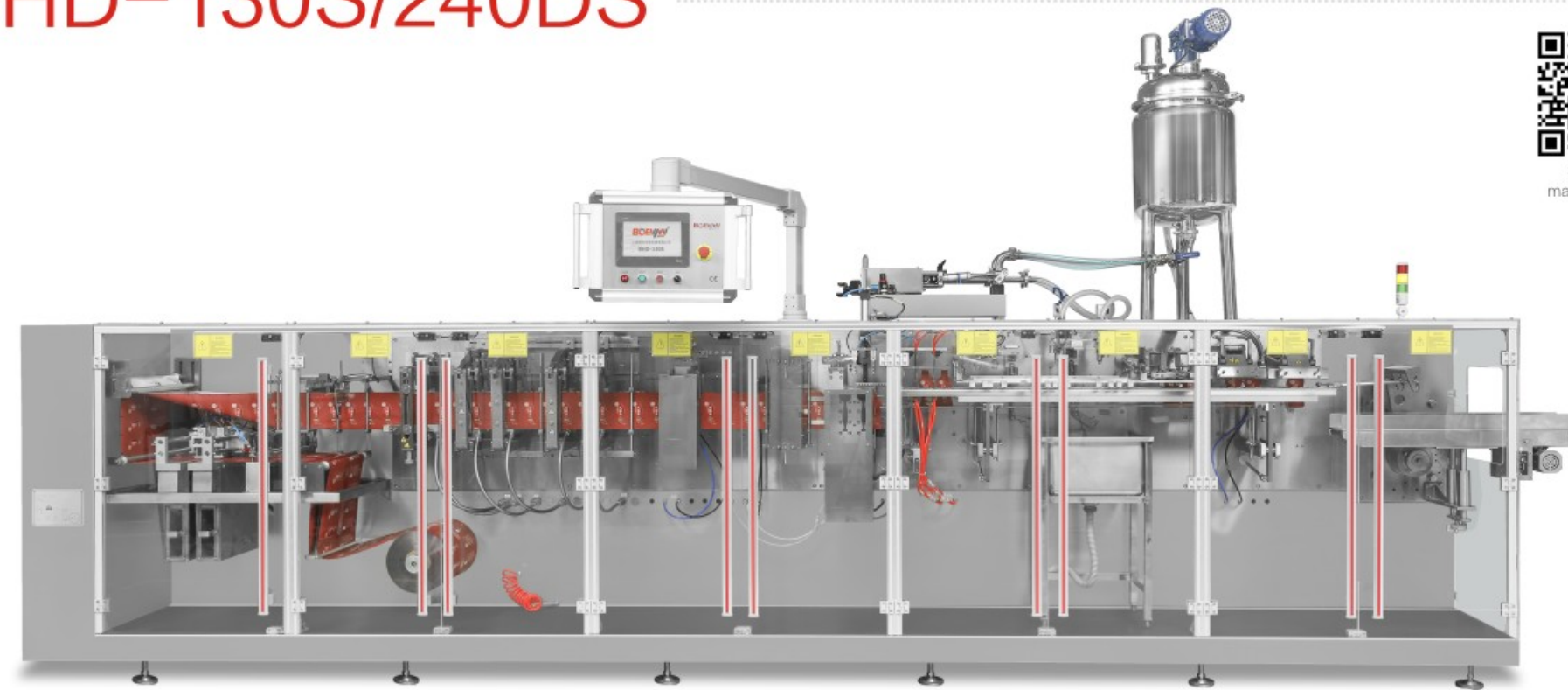

机器视频
machine video

技术参数 | Technical Parameter

| 型号 Model | 袋宽 Pouch Width | 袋长 Pouch Length | 包装容量范围 Filling Capacity | 包装速度 Packaging Capacity | 功能 Function | 重量 Weight | 功率 Power | 耗气量 Air Consumption | 设备尺寸 Machine Dimensions(L*W*H) |
|-------------|-------------------|--------------------|----------------------------|----------------------------|--------------------------|--------------|-------------|------------------------|-----------------------------------|
| BHD-130S | 60-130mm | 80-190mm | 350ml | 35-45ppm | 自立袋、异型 Doypack, Shape | 2150 kg | 6 kw | 300NL/min | 4720mm x 1125mm x 1550mm |
| BHD-240DS | 80-120mm | 120-250mm | 300ml | 70-90ppm | 自立袋、异型 Doypack, Shape | 2300 kg | 11 kw | 400 NL/min | 6050mm x 1002mm x 1990mm |

15 Web: www.boevan.com



包装流程 | Packing Process

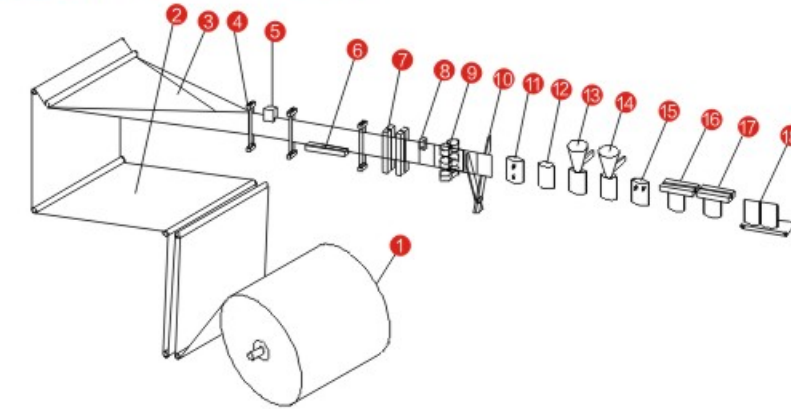

- 1 Film Unwinding Device
- 2 Bottom Hole Punching
- 3 Bag Forming Device
- 4 Film Guide Device
- 5 Photocell
- 6 Bottom Seal Unit
- 7 Vertical Seal
- 8 Tear Notch
- 9 Servo Pulling System
- 10 Cutting Knife
- 11 Pouch Opening Device
- 12 Air Flushing Device
- 13 Filling I
- 14 Filling II
- 15 Pouch Stretching
- 16 Top Sealing I
- 17 Top Sealing II
- 18 Outlet

产品优势 | Product Advantage



伺服牵袋系统
Servo Advance System
数字化规格切换，简单方便
Easy computerized specification change
牵袋更稳定，偏差更小
Stable pouch advance with less deviation
牵袋扭矩大，适合大规格
Big torque moment of pouch advance, suitable for big volume

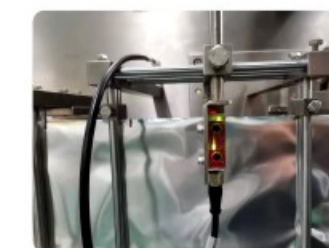

光电检测系统
Photocell System
全光谱检测，精准检测所有光源
Full spectrum detection, Accurate detection of all light sources
高速运动模式
High speed motion mode



异型功能
Shape Function
独特的异型装置设计
Special shape bar design
垂直放立，减少油耗
Vertical stand reduces fuel consumption

产品应用 | Product Application

BHD-130S/240DS系列专为自立袋需求而设计，并拥有灵活的功能应用，如：挂孔、异形、拉链、吸嘴等功能

BHD-130S/240DS Series designed for doypack, with functions of making hanging hole, special shape, zipper and spout.

粉末/Powder 颗粒/Granule 粘稠/Viscosity
固体/Solid 液体/Liquid 片剂/Tablet



E-mail: info@boevan.cn 16

水平包装机 Horizontal Packager

BHD-180S/SZ/SC

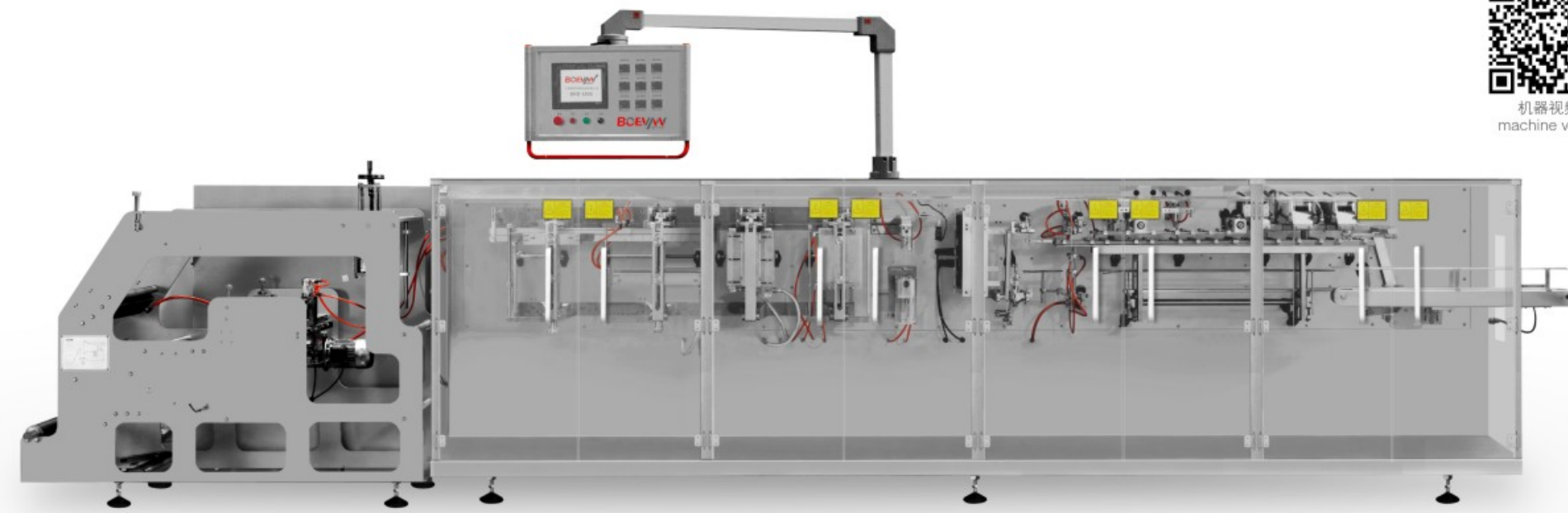

机器视频
machine video

技术参数 | Technical Parameter

| 型号 Model | 袋宽 Pouch Width | 袋长 Pouch Length | 包装容量范围 Filling Capacity | 包装速度 Packaging Capacity | 功能 Function | 重量 Weight | 功率 Power | 耗气量 Air Consumption | 设备尺寸 Machine Dimensions(L*W*H) |
|-------------|-------------------|--------------------|----------------------------|----------------------------|--|--------------|-------------|------------------------|-----------------------------------|
| BHD-180S | 90-180mm | 110-250mm | 1000ml | 40-60ppm | 自立袋、异形、挂孔 DoyPack, Shape, Hanging Hole | 2150kg | 9kw | 300 NL/min | 6093mm x 1083mm x 1908mm |
| BHD-180SZ | 90-180mm | 110-250mm | 1000ml | 40-60ppm | 自立袋、异形、挂孔、拉链 DoyPack, Shape, Hanging Hole, Zipper | 2150kg | 9kw | 300 NL/min | 6853mm x 1250mm x 1900mm |
| BHD-180SC | 90-180mm | 110-250mm | 1000ml | 40-60ppm | 自立袋、异形、挂孔、吸嘴 DoyPack, Shape, Hanging Hole, Spout | 2300kg | 9kw | 300 NL/min | 6853mm x 1250mm x 1900mm |

17 Web: www.boevan.com



包装流程 | Packing Process

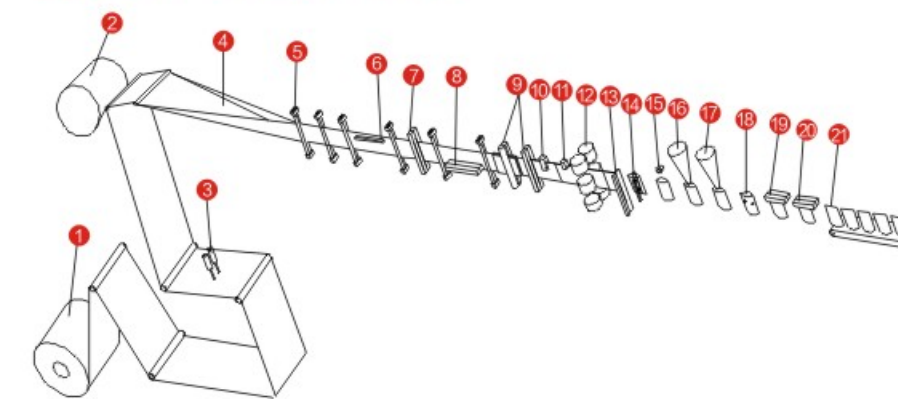

- 1 Film Unwinding Device
- 2 Zipper Roll
- 3 Bottom Hole Punching
- 4 Bag Forming Device
- 5 Film Guide
- 6 Zipper Horizontal Seal
- 7 Zipper Vertical Seal
- 8 Bottom Seal Unit
- 9 Vertical Seal
- 10 Tear Notch
- 11 Photocell
- 12 Servo Pulling System
- 13 Cutting Knife
- 14 Pouch Opening
- 15 Air Flushing Device
- 16 Filling I
- 17 Filling II
- 18 Pouch Stretching
- 19 Top Sealing I
- 20 Top Sealing II
- 21 Outlettear Notch

产品优势 | Product Advantage



伺服牵袋系统
Servo Advance System
数字化规格切换，简单方便
Easy computerized specification change
牵袋更稳定，偏差更小
Stable pouch advance with less deviation
牵袋扭矩大，适合大规格
Big torque moment of pouch advance, suitable for big volume



拉链功能
Zipper Function
独立的拉链放卷装置
Independent zipper unwind device
稳定的拉链张力控制
Stable zipper tensile force control
平整的拉链封合
Even zipper seal

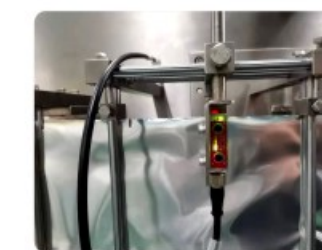

光电检测系统
Photocell System
全光谱检测，精准检测所有光源
Full spectrum detection, Accurate detection of all light sources
高速运动模式
High speed motion mode



产品应用 | Product Application

BHD-180系列专为自立袋需求而设计，并拥有灵活的功能应用，如：挂孔、异形、拉链、吸嘴等功能

BHD-180 Series designed for doypack, with functions of making hanging hole, special shape, zipper and spout.

粉末/Powder 颗粒/Granule 粘稠/Viscosity
固体/Solid 液体/Liquid 片剂/Tablet

水平包装机 Horizontal Packager

BHD-240S/SZ/SC

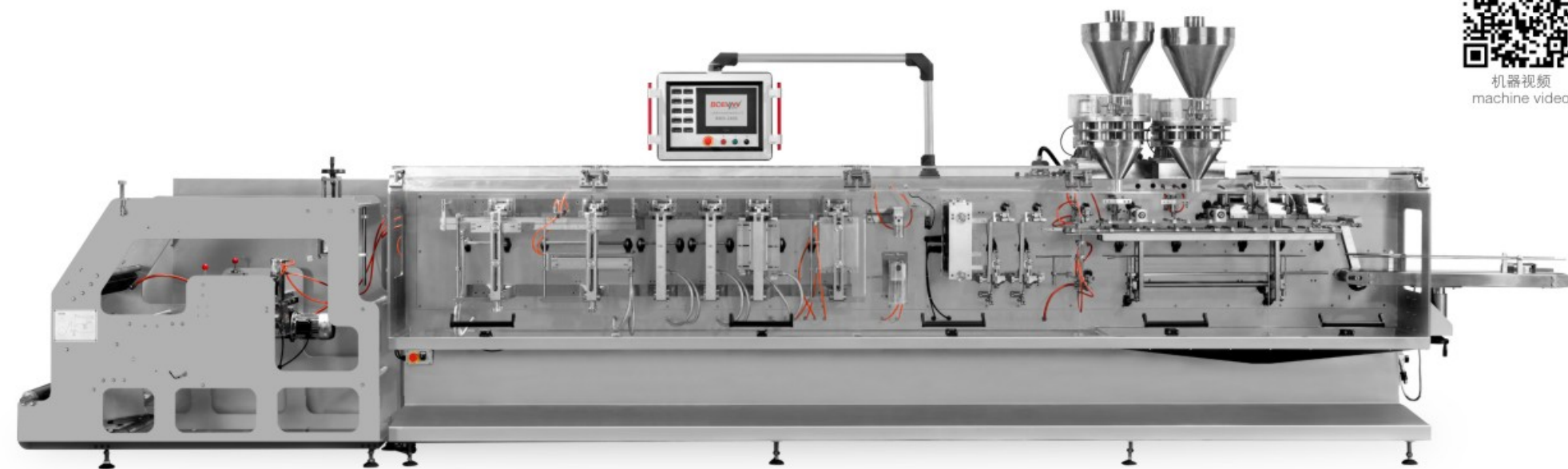

机器视频
machine video

技术参数 | Technical Parameter

| 型号 Model | 袋宽 Pouch Width | 袋长 Pouch Length | 包装容量范围 Filling Capacity | 包装速度 Packaging Capacity | 功能 Function | 重量 Weight | 功率 Power | 耗气量 Air Consumption | 设备尺寸 Machine Dimensions(L*W*H) |
|-------------|-------------------|--------------------|----------------------------|----------------------------|---|--------------|-------------|------------------------|-----------------------------------|
| BHD-240S | 100-240mm | 120-320mm | 2000ml | 40-60ppm | 自立袋、异型、挂孔 DoyPack, Shape, Hanging Hole, | 2300kg | 11kw | 400 NL/min | 7000 x 1243 x 1878mm |
| BHD-240SZ | 100-240mm | 120-320mm | 2000ml | 40-60ppm | 自立袋、异型、挂孔、拉链 DoyPack, Shape, Hanging Hole, Zipper | 2500kg | 11kw | 400 NL/min | 7736 x 1243 x 1878mm |
| BHD-240SC | 100-240mm | 120-320mm | 2000ml | 40-60ppm | 自立袋、异型、挂孔、吸嘴 DoyPack, Shape, Hanging Hole, Spout | 2500kg | 11kw | 400 NL/min | 8100 x 1243 x 1878mm |

19 Web: www.boevan.com



包装流程 | Packing Process

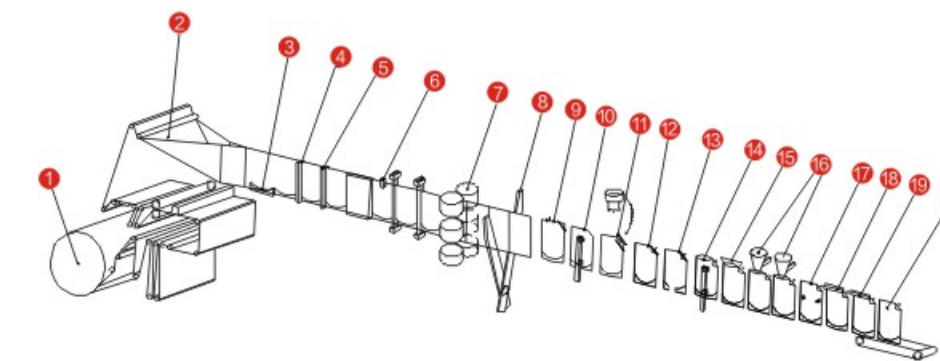

- 1 Film Unwinding Device
- 2 Bag Forming Device
- 3 Bottom Seal Unit
- 4 Vertical Sealing I
- 5 Vertical Sealing II
- 6 Photocell
- 7 Servo Pulling System
- 8 Cutting Knife
- 9 Slant Opening Cutting
- 10 Pouch First Opening
- 11 Spout Inserting
- 12 Spout Sealing I
- 13 Spout Sealing II
- 14 Pouch Opening Device
- 15 Air Flushing Device
- 16 Filling
- 17 Pouch Stretching
- 18 Top Sealing I
- 19 Top Sealing II
- 20 Outlet

产品优势 | Product Advantage



伺服牵袋系统
Servo Advance System
数字化规格切换，简单方便
Easy computerized specification change
牵袋更稳定，偏差更小
Stable pouch advance with less deviation
牵袋扭矩大，适合大规格
Big torque moment of pouch advance,
suitable for big volume



吸嘴功能
Spout Function
平整美观的吸嘴封合
Even spout seal with good appearance
吸嘴封合强度高，无泄漏
High spout seal strength, no leakage



光电检测系统
Photocell System
全光谱检测，精准检测所有光源
Full spectrum detection, Accurate
detection of all light sources
高速运动模式
High speed motion mode

产品应用 | Product Application

BHD-240系列专门为大规模自立袋需求而设计，满足大规模包装需求，并拥有灵活的功能应用，如加挂钩、异型、拉链、吸嘴等功能。

BHD-240 Series designed for big volume doypack, with functions of making hanging hole, special shape, zipper and spout.

粉末/Powder 颗粒/Granule 粘稠/Viscosity
固体/Solid 液体/Liquid 片剂/Tablet



E-mail: info@boevan.cn 20

水平包装机 Horizontal Packager

BHD-280DS/DSZ/DSC

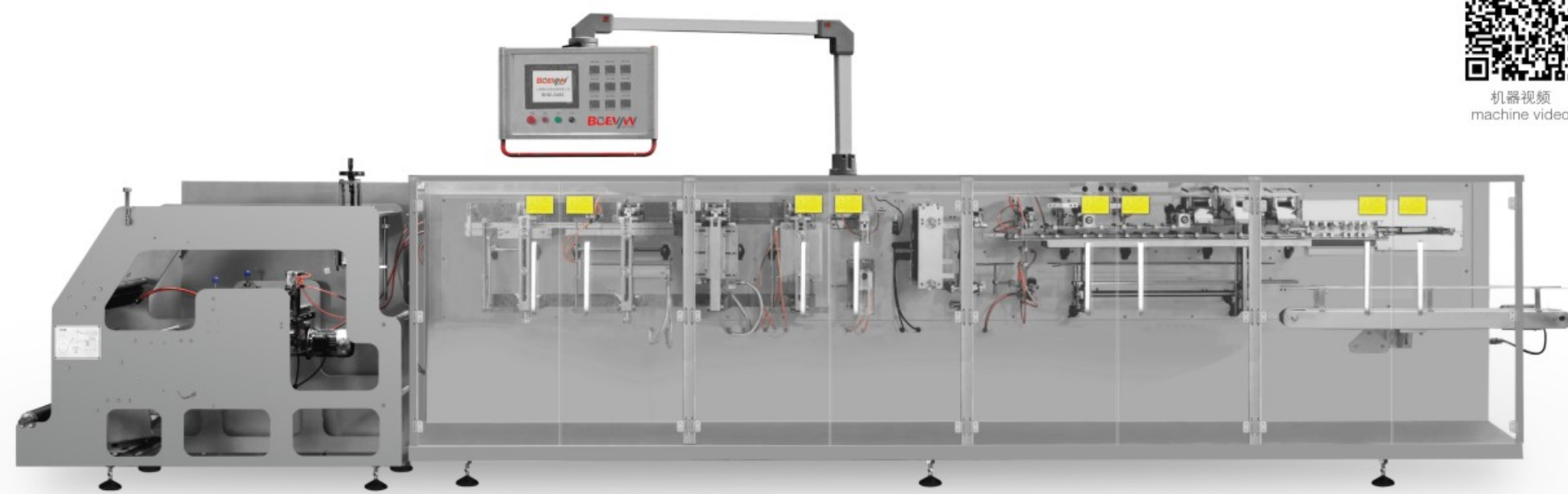

机器视频
machine video

技术参数 | Technical Parameter

| 型号 Model | 袋宽 Pouch Width | 袋长 Pouch Length | 包装容量范围 Filling Capacity | 包装速度 Packaging Capacity | 功能 Function | 重量 Weight | 功率 Power | 耗气量 Air Consumption | 设备尺寸 Machine Dimensions(L*W*H) |
|-------------|-------------------|--------------------|----------------------------|----------------------------|---|--------------|-------------|------------------------|-----------------------------------|
| BHD-280DS | 90-140mm | 110-250mm | 500ml | 80-100ppm | 自立袋、异型、挂孔 DoyPack, Shape, Hanging Hole, | 2150kg | 15.5kw | 400 NL/min | 7800 x 1300 x 1878mm |
| BHD-280DSC | 90-140mm | 110-250mm | 500ml | 80-100ppm | 自立袋、异型、挂孔、拉链 DoyPack, Shape, Hanging Hole, Zipper | 2150kg | 15.5kw | 400 NL/min | 7736 x 1300 x 1878mm |
| BHD-280DSZ | 90-140mm | 110-250mm | 500ml | 80-100ppm | 自立袋、异型、挂孔、吸嘴 DoyPack, Shape, Hanging Hole, Spout | 2150kg | 15.5kw | 400 NL/min | 8200 x 1300 x 1878mm |

21 Web: www.boevan.com



包装流程 | Packing Process

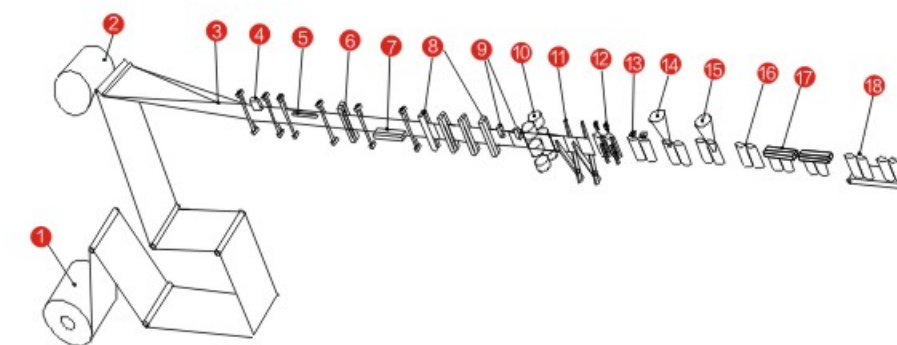

- 1 Film Unwinding Device
- 2 Zipper Roll
- 3 Bag Forming Device
- 4 Photocell
- 5 Zipper Horizontal Seal
- 6 Zipper Vertical Seal
- 7 Bottom Seal Unit
- 8 Vertical Seal
- 9 Tear Notch
- 10 Servo Pulling System
- 11 Cutting Knife
- 12 Pouch Opening
- 13 Air Flushing Device
- 14 Filling I
- 15 Filling II
- 16 Pouch Stretching
- 17 Top Sealing
- 18 Outlet

产品优势 | Product Advantage



**双出模式设计
Duplex Design**
运行稳定, 调整方便
Stable operation, easy adjustment
一次出两袋, 产能翻倍
2 pouches at the same time,
double productivity



**拉链功能
Zipper Function**
独立的拉链放卷装置
Independent zipper unwind device
稳定的拉链张力控制
Stable zipper tensile force control
平整的拉链封合
Even zipper seal

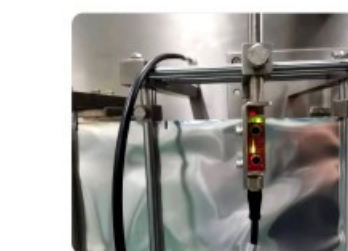

**光电检测系统
Photocell System**
全光谱检测, 精准检测所有光源
Full spectrum detection, Accurate
detection of all light sources
高速运动模式
High speed motion mode

产品应用 | Product Application

BHD-280D系列拥有双出模式设计与自立袋功能, 最高速度120袋/分钟。同时满足客户多功能的包装需求, 如加挂钩、异型、拉链、吸嘴等。

BHD-280D Series doypack function & duplex design with Max speed 120ppm. With additional functions of hanging hole, special shape, zipper and spout.

粉末/Powder 颗粒/Granule 粘稠/Viscosity
固体/Solid 液体/Liquid 片剂/Tablet



E-mail: info@boevan.cn 22

水平包装机 Horizontal Packager

BHP-200

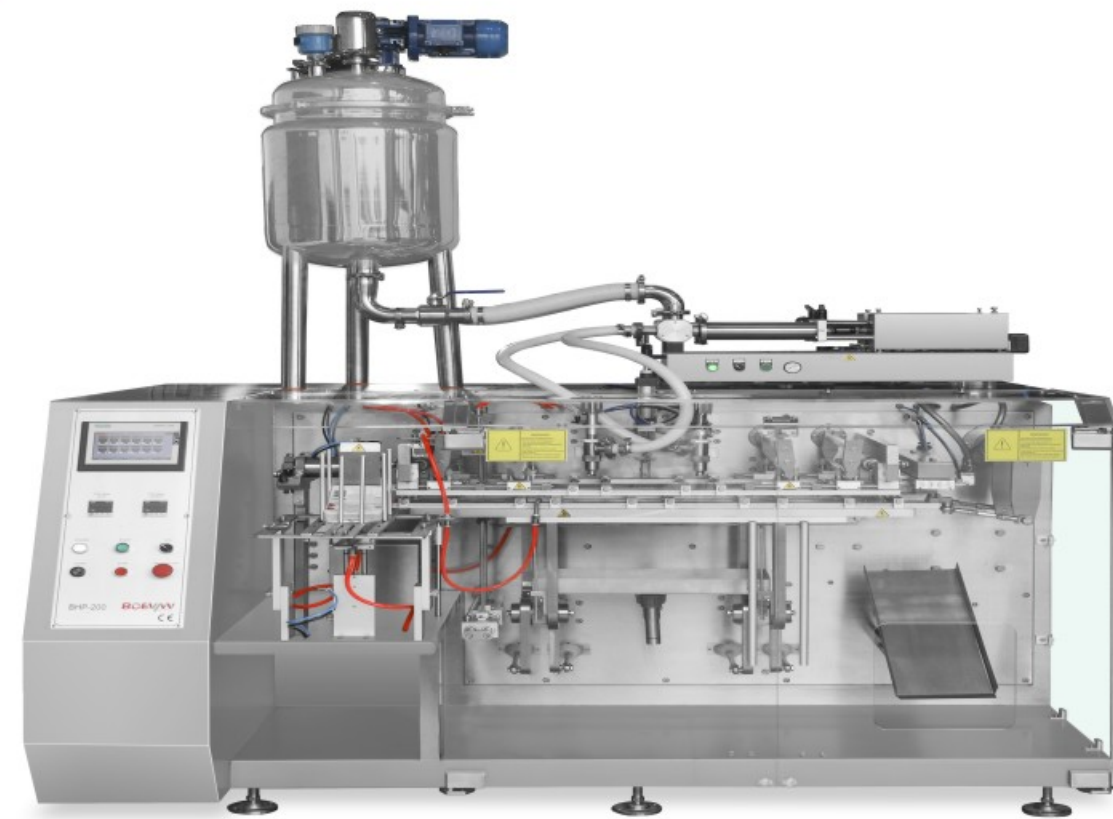

机器视频
machine video

技术参数 | Technical Parameter

| 型号 Model | 袋宽 Pouch Width | 袋长 Pouch Length | 包装容量范围 Filling Capacity | 包装速度 Packaging Capacity | 功能 Function | 重量 Weight | 功率 Power | 耗气量 Air Consumption | 设备尺寸 Machine Dimensions(L*W*H) |
|-------------|-------------------|--------------------|----------------------------|----------------------------|---|--------------|-------------|------------------------|-----------------------------------|
| BHP-200 | 90-200mm | 110-300mm | 1200ml | 40-60ppm | 平袋、三边封、四边封、挂孔、异形 Flat Pouch、3/4 side seal、 Hanging Hole、Shape | 900kg | 2.3 kw | 200 NL/min | 2110 x 1200 x 1690mm |

23 Web:www.boevan.com



食品 Food 化妆 Cosmetics 化工 Chemical 饮料 Beverages 制药 Pharma

包装流程 | Packing Process

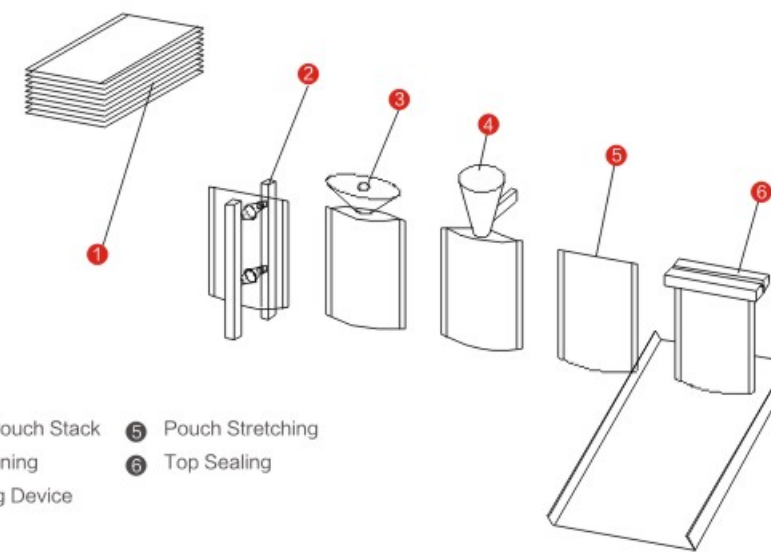

- 1 Premade Pouch Stack
- 2 Pouch Opening
- 3 Air Flushing Device
- 4 Filling
- 5 Pouch Stretching
- 6 Top Sealing

产品优势 | Product Advantage



双下料结构
Duplex Filling Nozzle
高速
High speed
高精度
High accuracy



轻盈化小车
Light Walking Beam
更高的运行速度
Higher running speed
更长的使用寿命
Longer operational life span

产品应用 | Product Application

BHP-200 给袋包装机, 适用于中、小型平袋包装, 实现灵活、经济的包装解决方案。

BHP-200 premade pouch packing machine, designed for middle & small size bags, offer flexible and economical solution for flat packing.

粉末/Powder 颗粒/Granule 粘稠/Viscosity
固体/Solid 液体/Liquid 片剂/Tablet



E-mail: info@boevan.cn 24

水平包装机 Horizontal Packager

BHP-210/Z、240/Z

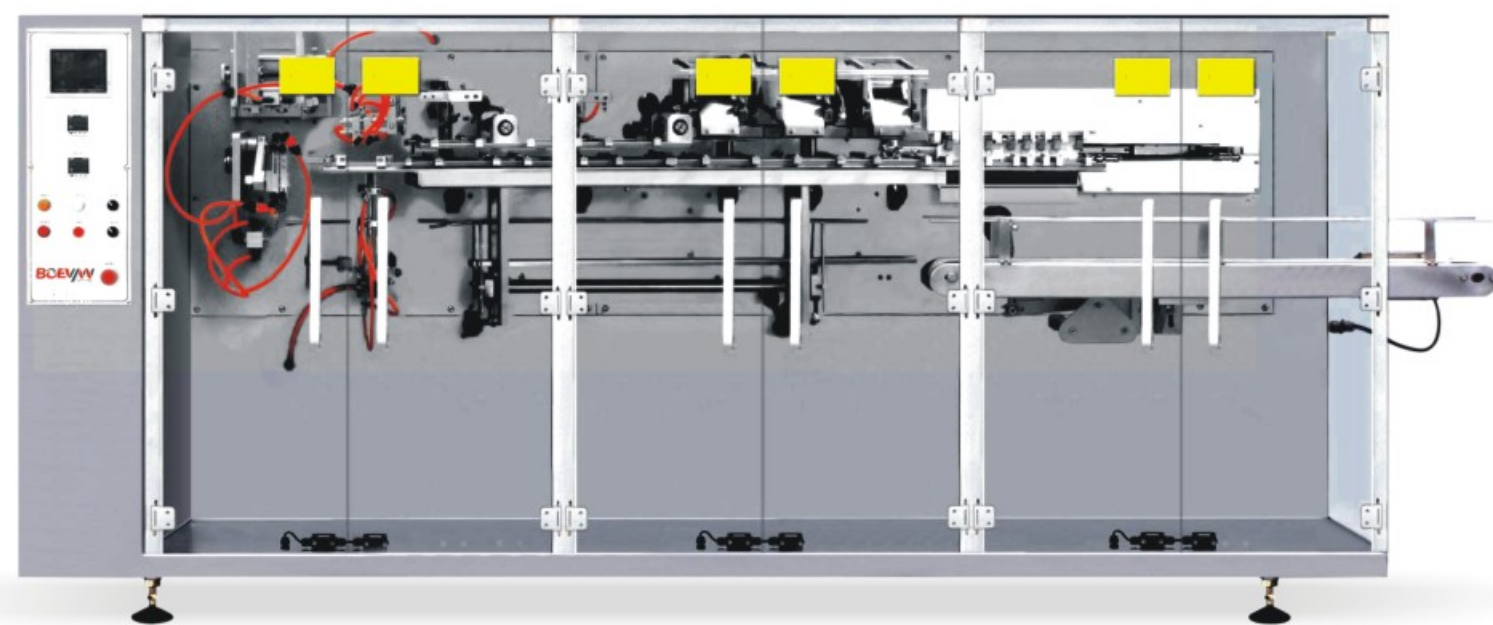

机器视频
machine video

技术参数 | Technical Parameter

| 型号 Model | 袋宽 Pouch Width | 袋长 Pouch Length | 包装容量范围 Filling Capacity | 包装速度 Packaging Capacity | 功能 Function | 重量 Weight | 功率 Power | 耗气量 Air Consumption | 设备尺寸 Machine Dimensions(L*W*H) |
|-------------|-------------------|--------------------|----------------------------|----------------------------|---|--------------|-------------|------------------------|-----------------------------------|
| BHP-210Z | 90-210mm | 110-300mm | 1500ml | 40-60ppm | 平袋、自立袋、拉链、自立袋斜吸嘴 Flat Pouch, DoyPack, Doypack with corner spout | 1100kg | 4.5 kw | 350 NL/min | 3216 x 1190 x 1422mm |
| BHP-240Z | 100-240mm | 120-320mm | 2000ml | 40-60ppm | 平袋、自立袋、拉链、自立袋斜吸嘴 Flat Pouch, DoyPack, Doypack with corner spout | 2300kg | 4.5 kw | 350 NL/min | 4015 x 1508 x 1240mm |

25 Web:www.boevan.com



包装流程 | Packing Process

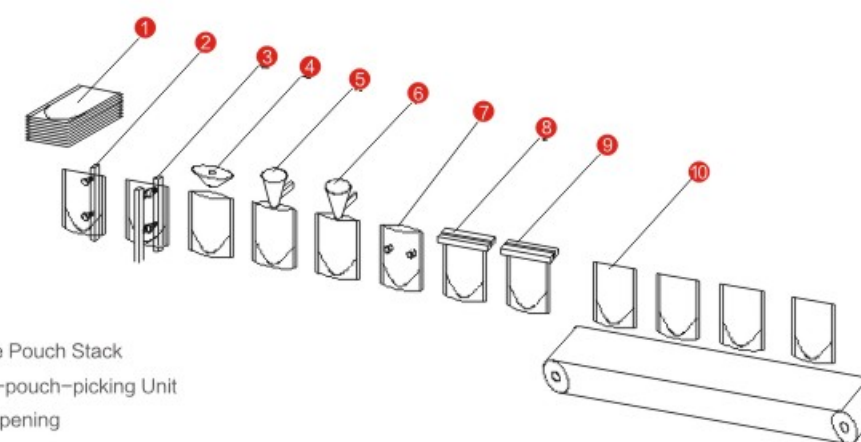

- 1 Premade Pouch Stack
- 2 Flip-out-pouch-picking Unit
- 3 Pouch Opening
- 4 Air Flushing
- 5 Filling I
- 6 Filling II
- 7 Auxiliary Pouch Stretching
- 8 Top Sealing I
- 9 Top Sealing II
- 10 Outlet

产品优势 | Product Advantage



**双工位下料
Dual Filling Station**
缩短一半下料时间
Reduce filling time by half
提高下料精度
Improved filling accuracy

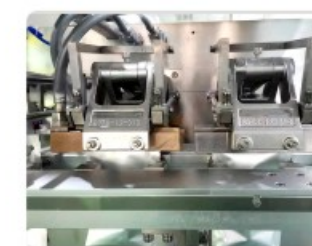

**三组顶封装置
3-pair Top Seal Unit**
确保封合强度，无泄漏
Ensure seal strength, no leakage
封口平整、美观
Even seal with good appearance



**开袋检测装置
Air Flushing Device**
辅助吹气，提高开袋率
Auxiliary blowing, improve bag opening success rate
检测功能，无袋不下料，不封口
No bag opening good, no filling, no sealing

产品应用 | Product Application

BHP-210/240系列给袋包装机，适用于平袋和自立袋包装，实现灵活、经济的包装解决方案。

BHP-210/240 Series premade pouch packing machine, offer flexible and economical solution for flat and doypack packing.

粉末/Powder 颗粒/Granule 粘稠/Viscosity
固体/Solid 液体/Liquid 片剂/Tablet



E-mail: info@boevan.cn 26

水平包装机 Horizontal Packager

BHP-210D/280D/280DZ

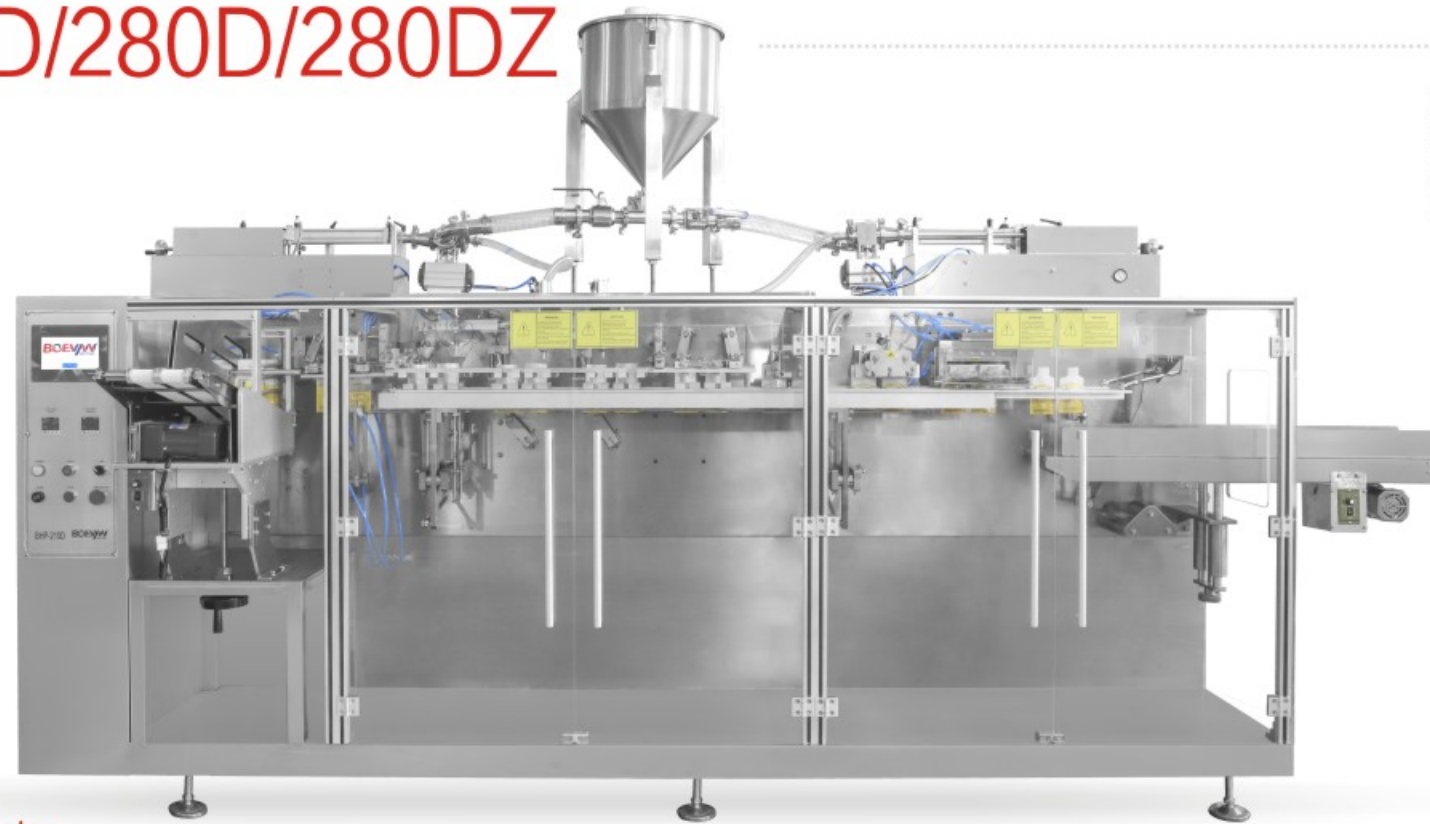

机器视频
machine video

技术参数 | Technical Parameter

| 型号 Model | 袋宽 Pouch Width | 袋长 Pouch Length | 包装容量范围 Filling Capacity | 包装速度 Packaging Capacity | 功能 Function | 重量 Weight | 功率 Power | 耗气量 Air Consumption | 设备尺寸 Machine Dimensions(L*W*H) |
|-------------|-------------------|--------------------|----------------------------|----------------------------|--|--------------|-------------|------------------------|-----------------------------------|
| BHP-210D | 75-105mm | 110-300mm | 400ml | 80-100ppm | 平袋、自立袋 Flat Pouch, DoyPack | 1100kg | 4.5 kw | 200 NL/min | 3216 × 1190 × 1422mm |
| BHP-280D | 90-140mm | 110-300mm | 600ml | 80-100ppm | 平袋、自立袋 Flat Pouch, DoyPack | 2150kg | 4.5 kw | 500 NL/min | 4300 × 970 × 1388mm |
| BHP-280DZ | 90-140mm | 110-300mm | 600ml | 80-100ppm | 平袋、自立袋、拉链 Flat Pouch, DoyPack, Zipper | 2150kg | 4.5 kw | 500 NL/min | 4300 × 970 × 1388mm |

27 Web:www.boevan.com



包装流程 | Packing Process

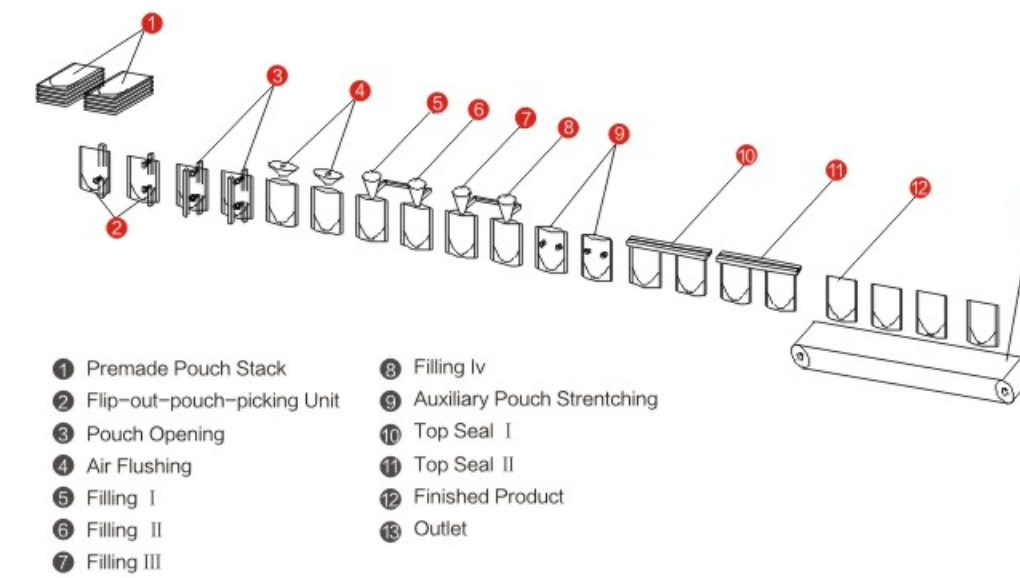

产品优势 | Product Advantage



**双工位下料
Dual Filling Station**
缩短一半下料时间
Reduce filling time by half
提高下料精度
Improved filling accuracy



**两组顶封装置
2-Pair Top Seal Unit**
确保封合强度, 无泄漏
Ensure seal strength, no leakage
封口平整、美观
Even seal with good appearance
更高薄膜适应性
Higher adaptability of film material



**光电检测系统
Photocell System**
全光谱检测, 精准检测所有光源
Full spectrum detection, Accurate detection of all light sources
高速运动模式
High speed motion mode

产品应用 | Product Application

BHP-210D/280D/280DZ 给袋式包装机拥有双出模式设计, 最高速度120袋/分钟, 适用于平袋和自立袋包装, 实现高速、灵活、经济的包装解决方案。

BHP-210D/280D/280DZ Series premade & duplex design with Max speed 120ppm, offer flexible and economical solution for flat and doypack packing.

粉末/Powder 颗粒/Granule 粘稠/Viscosity
固体/Solid 液体/Liquid 片剂/Tablet



E-mail: info@boevan.cn 28

旋转给袋机 Rotary bag feeder

BRS-4S



机器视频
machine video



技术参数 | Technical Parameter

| 机型 Model | BRS-4S | BRS-6S |
|------------------------|----------------------|----------------------|
| 头数 Head number | 4 | 6 |
| 最大袋宽 Max bag width | 250mm | 250mm |
| 最大袋高 Max bag height | 300mm | 300mm |
| 喷嘴直径 Nozzle diameter | 8.5-20mm | 8.5-20mm |
| 最大装量 Maximum loading | 2000ml | 2000ml |
| 包装速度 Packaging speed | 100ml/5200-5500pph | 100ml/7800-8200pph |
| | 300ml/4600-4800pph | 300ml/6900-7200pph |
| | 500ml/3800-4000pph | 500ml/5700-6000pph |
| 计量精度 Metering accuracy | < ± 1.0% | < ± 1.0% |
| 耗电功率 Power consumption | 4.5KW | 4.5KW |
| 耗气量 Gas consumption | 400NL/min | 500NL/min |
| 设备尺寸 (L×W×H) | 1550mm*2200mm*2400mm | 2100mm*2600mm*2800mm |

电气配置 | Electrical configuration

| 主要部件 Main Components | 供应商 Supplier |
|------------------------|--------------------------|
| PLC | 施耐德 Schneider |
| 触摸屏 Touch Screen | 施耐德 Schneider |
| 变频器 Inverter | 施耐德 Schneider |
| 伺服电机 Servo Motor | 施耐德 Schneider |
| 光标检测 Photocell | Autonics Korea 邦纳 BANNER |
| 主电机 Main Motor | 瑞士 ABB ABB Switzerland |
| 气动元件 Pneumatic Parts | 日本 SMC SMC Japan |
| 真空发生器 Vacuum Generator | 日本 SMC SMC Japan |



包装流程 | Packing Process

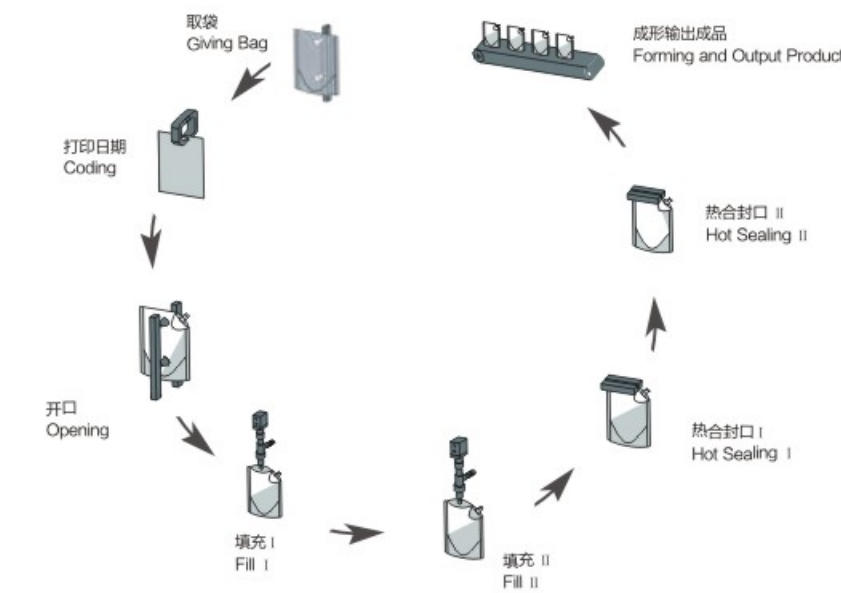

产品优势 | Product Advantage



独特的填充喷嘴设计
Unique Filling Nozzle Design

- 高填充精度 High filling accuracy
- 充填后无滴液 No drop after filling
- 高速度 High velocity



独特的旋盖系统
Unique Capping System

- 固定扭矩旋盖 Fixed torque cover
- 旋盖运行稳定 Rotary cover stability
- 无损坏盖帽或喷嘴 No damage cap or nozzle



下料装置
Filling Nozzle Design

- 高精度 好速度 High filling accuracy, high speed
- 不滴料 不漏料 No drop and no leakage

产品应用 | Product Application

BRS-4S采用四出运转模式，速度为60袋/分钟
BRS-4S with 4 heads filling nozzle, speed about 60bags/min

粉末/Powder 颗粒/Granule 粘稠/Viscosity
固体/Solid 液体/Liquid 片剂/Tablet



水平包装机 Horizontal Packager

BHS-110/130

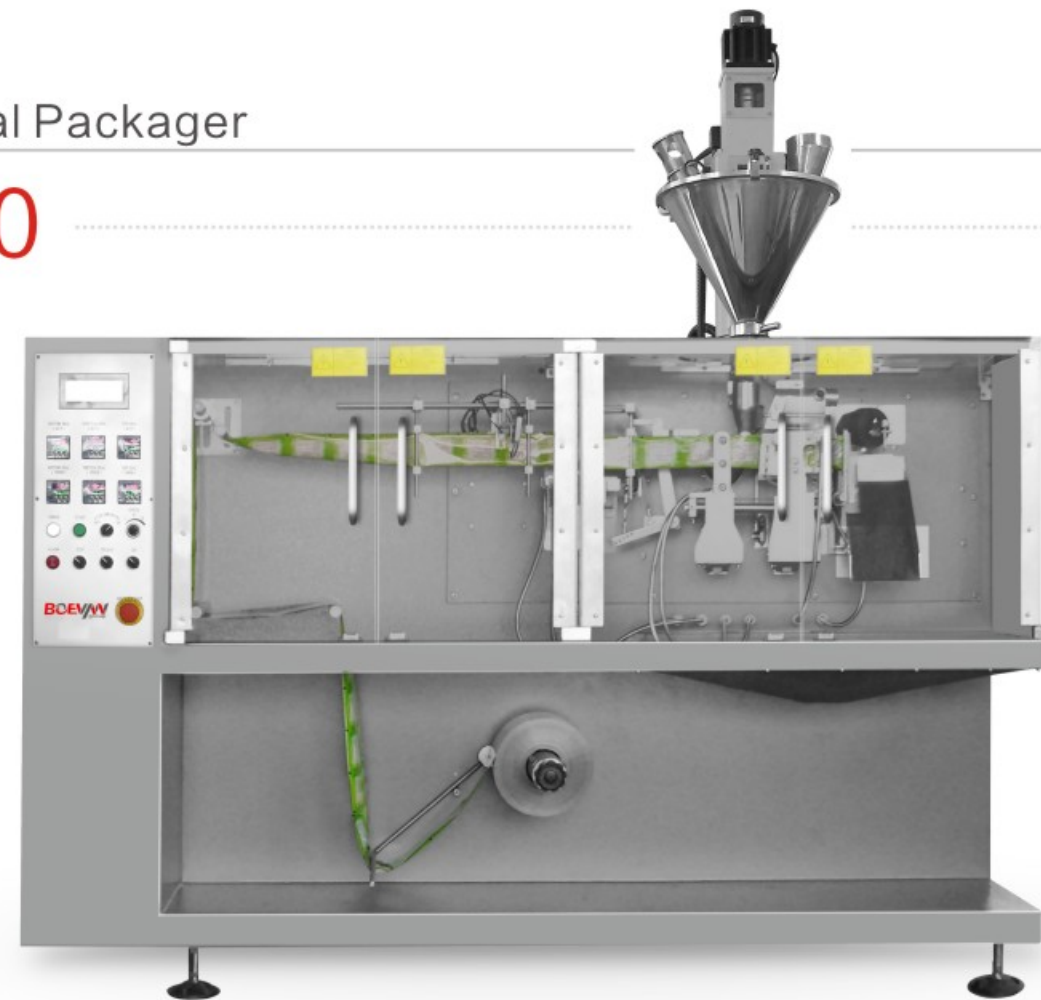

机器视频
machine video

技术参数 | Technical Parameter

| 型号 Model | 袋宽 Pouch Width | 袋长 Pouch Length | 包装容量范围 Filling Capacity | 包装速度 Packaging Capacity | 功能 Function | 重量 Weight | 功率 Power | 耗气量 Air Consumption | 设备尺寸 Machine Dimensions(L*W*H) |
|-------------|-------------------|--------------------|----------------------------|----------------------------|--------------------------------------|--------------|-------------|------------------------|-----------------------------------|
| BHS-110 | 50-110mm | 50-130mm | 60ml | 40-60ppm | 三边封, 四边封 3 side seal, 4 side seal | 480kg | 3.5 kw | 100 NL/min | 2060 x 750 x 1335mm |
| BHS-130 | 60-140mm | 80-220mm | 400ml | 40-60ppm | 三边封, 四边封 3 side seal, 4 side seal | 600kg | 3.5 kw | 100 NL/min | 2885 x 970 x 1535mm |

31 Web: www.boevan.com

食品 Food 化妆 Cosmetics 化工 Chemical 饮料 Beverages 制药 Pharma

BOEVAN
pack

包装流程 | Packing Process

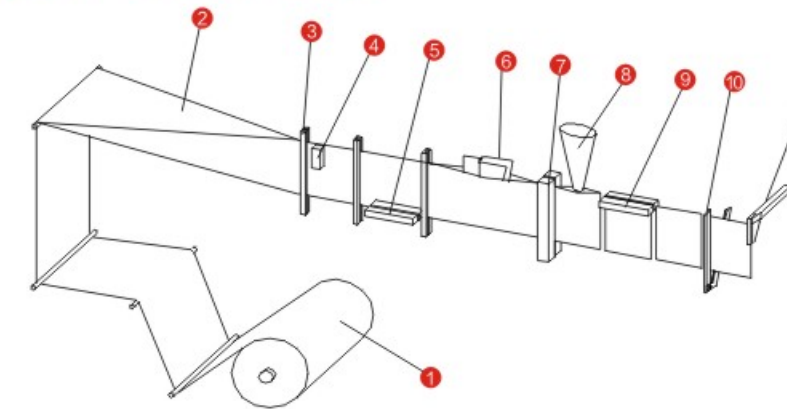

- 1 Film Unwinding Device
- 2 Bag Forming Device
- 3 Film Guide
- 4 Photocell
- 5 Bottom Seal
- 6 Pouch Opening
- 7 Vertical Seal
- 8 Filling Device
- 9 Top Seal
- 10 Cutting Device
- 11 Pouch Pulling

产品优势 | Product Advantage



独立的封合装置
Independent Sealing Device
独立制袋, 封边无夹料
Independent pouch making, no product no seal
更高的封合强度, 减少漏袋
Higher seal strength, less leakage
袋子更平整更美
Better pouch appearance



轻盈化小车
Light Walking Beam
更高的运行速度
Higher running speed
更长的使用寿命
Longer operational life span

产品应用 | Product Application

BHS-110/130 是针对小袋包装而设计的基本机型。包装效果完美, 设备灵活。

BHS-110/130 Standard model for small bags, flexible design for nice packing appearance.

粉末/Powder 颗粒/Granule 粘稠/Viscosity
固体/Solid 液体/Liquid 片剂/Tablet



E-mail: info@boevan.cn 32

水平包装机 Horizontal Packager

BHS-180/180T

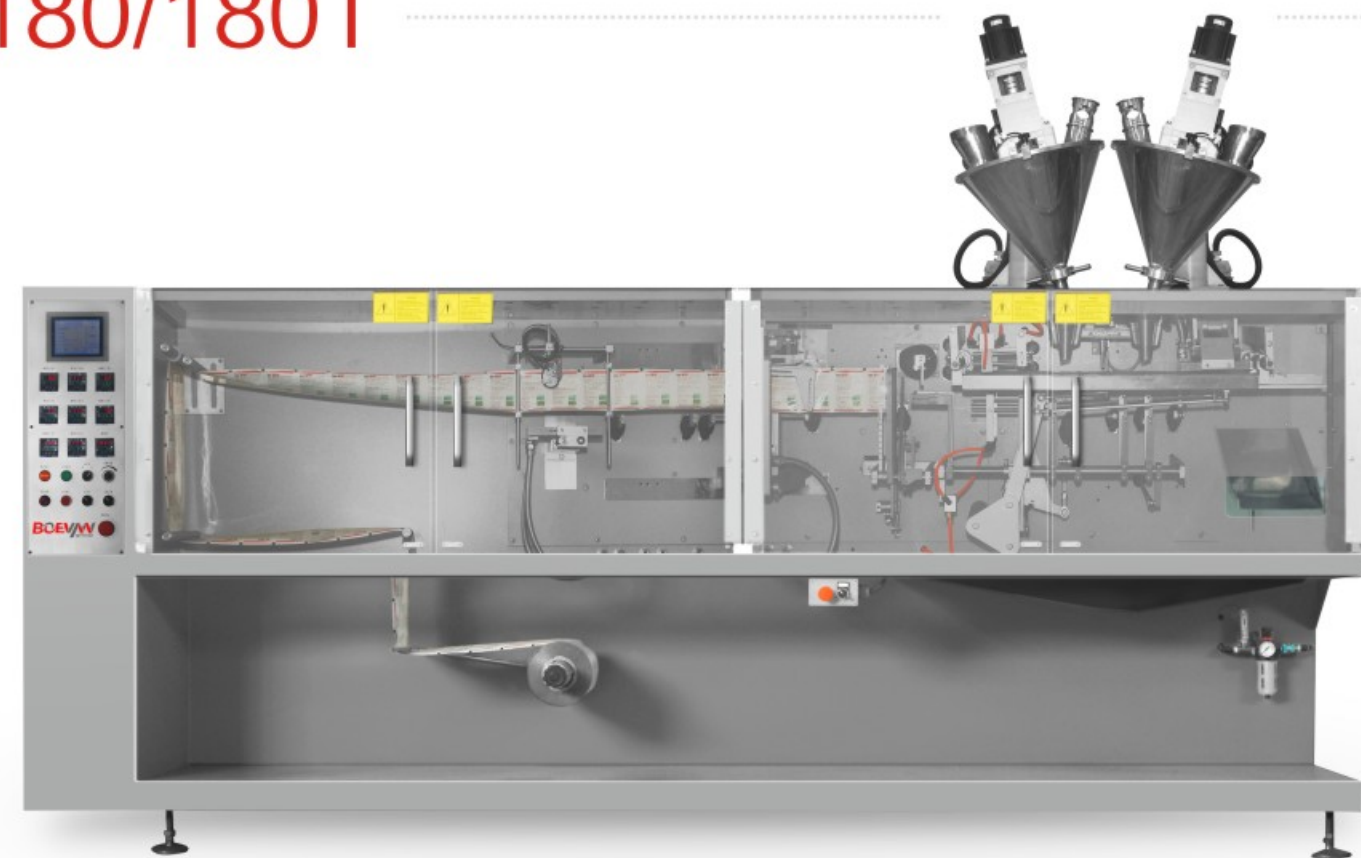

机器视频
machine video

技术参数 | Technical Parameter

| 型号 Model | 袋宽 Pouch Width | 袋长 Pouch Length | 包装容量范围 Filling Capacity | 包装速度 Packaging Capacity | 功能 Function | 重量 Weight | 功率 Power | 耗气量 Air Consumption | 设备尺寸 Machine Dimensions(L*W*H) |
|-------------|-------------------|--------------------|----------------------------|----------------------------|---|--------------|-------------|------------------------|-----------------------------------|
| BHS-180 | 60-180mm | 80-225mm | 500ml | 40-60ppm | 三边封, 四边封 3 side seal, 4 side seal | 1250kg | 4.5 kw | 200 NL/min | 3500 x 970 x 1530mm |
| BHS-180T | 60-90mm | 80-225mm | 100ml | 40-60ppm | 三边封, 四边封, 双联袋 3 side seal, 4 side seal, Twin Bag | 1250kg | 4.5 kw | 200 NL/min | 3500 x 970 x 1530mm |

33 Web:www.boevan.com



包装流程 | Packing Process

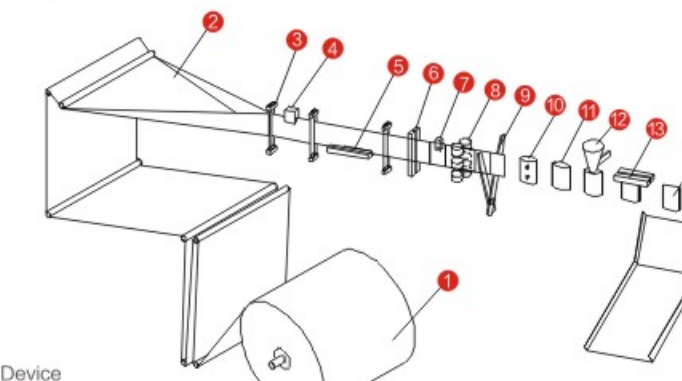

- 1 Film Unwinding Device
- 2 Bag Forming Device
- 3 Film Guide
- 4 Photocell
- 5 Bottom Sealing
- 6 Vertical Sealing
- 7 Tear Notch
- 8 Servo Pulling System(optional)
- 9 Pouch Cutting
- 10 Pouch Opening
- 11 Air Flushing Device
- 12 Filling Device
- 13 Top Sealing
- 14 Outlet

产品优势 | Product Advantage



独立的封合装置
Independent Sealing Device
独立制袋, 封边无夹料
Independent pouch making, no product no seal
更高的封合强度, 减少漏袋
Higher seal strength, less leakage
袋子更平整更美
Better pouch appearance



轻盈化小车
Light Walking Beam
更高的运行速度
Higher running speed
更长的使用寿命
Longer operational life span

产品应用 | Product Application

BHS-180 系列为中、小袋包装而设计, 拥有双工位下料及可以双联袋功能, 出色解决中、小袋包装的高速需求。

BHS-180 Series designed for middle& small size bags, dual filling station and twin-link function, excellent for high speed packing requirement.

粉末/Powder 颗粒/Granule 粘稠/Viscosity
固体/Solid 液体/Liquid 片剂/Tablet



水平包装机 Horizontal Packager

BHS-210D/240D

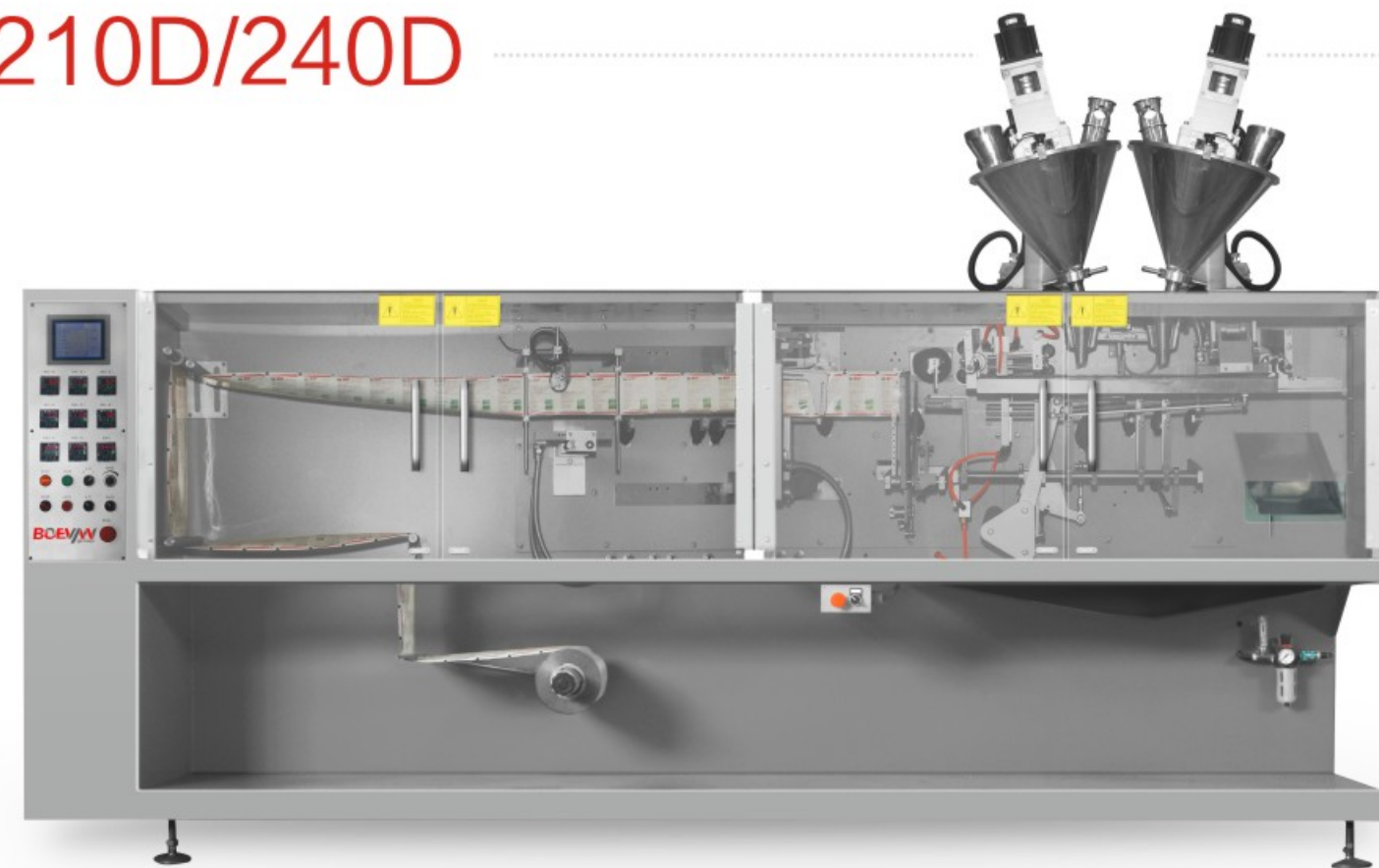

机器视频
machine video

技术参数 | Technical Parameter

| 型号 Model | 袋宽 Pouch Width | 袋长 Pouch Length | 包装容量范围 Filling Capacity | 包装速度 Packaging Capacity | 功能 Function | 重量 Weight | 功率 Power | 耗气量 Air Consumption | 设备尺寸 Machine Dimensions(L*W*H) |
|-------------|-------------------|--------------------|----------------------------|----------------------------|--------------------------------------|--------------|-------------|------------------------|-----------------------------------|
| BHS-210D | 60-105mm | 90-225mm | 150ml | 80-100ppm | 三边封, 四边封 3 side seal, 4 side seal | 1250kg | 4.5 kw | 200 NL/min | 4300 x 970 x 1500mm |
| BHS-240D | 70-120mm | 100-225mm | 180ml | 80-100ppm | 三边封, 四边封 3 side seal, 4 side seal | 1250kg | 4.5 kw | 200 NL/min | 4500 x 970 x 1500mm |

35 Web:www.boevan.com



- 食品 Food
- 化妆 Cosmetics
- 化工 Chemical
- 饮料 Beverages
- 制药 Pharma

包装流程 | Packing Process

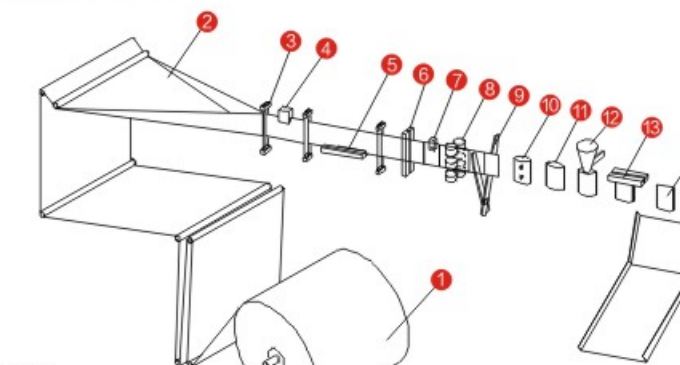

- 1 Film Unwinding Device
- 2 Bag Forming Device
- 3 Film Guide
- 4 Photocell
- 5 Bottom Seal
- 6 Vertical Seal
- 7 Tear Notch
- 8 Servo Pulling System(optional)
- 9 Pouch Cutting
- 10 Pouch Opening
- 11 Air Flushing Device
- 12 Filling Device
- 13 Top Seal Device
- 14 Outlet

产品优势 | Product Advantage



独立的封合装置
Independent Sealing Device
独立制袋, 封边无夹料
Independent pouch making, no product no seal
更高的封合强度, 减少漏袋
Higher seal strength, less leakage
袋子更平整更美
Better pouch appearance



轻盈化小车
Light Walking Beam
更高的运行速度
Higher running speed
更长的使用寿命
Longer operational life span



双工位下料
Dual Filling Station
缩短一半下料时间
Reduce filling time by half
提高下料精度
Improved filling accuracy

产品应用 | Product Application

BHS-210D/240D 系列为中、小袋包装而设计, 拥有双工位下料及可以双联袋功能, 出色解决中、小袋包装的高速需求。

BHS-210D/240D Series designed for middle& small size bags, dual filling station and twin-link function, excellent for high speed packing requirement.

- 粉末/Powder
- 颗粒/Granule
- 粘稠/Viscosity
- 固体/Solid
- 液体/Liquid
- 片剂/Tablet



立式包装机 Vertical Packager

立式条包单列机 Vertical Single Lane Stick Bag Packager



设备特点 | Equipment Characteristics

本自动包装机可自动完成产品多列自动定量计量、自动充填，自动制袋，封口，切断、打印生产日期等功能。伺服电机驱动热封式拉膜，稳定可靠，精确度高。高灵敏度电眼可自动追踪定位印刷光标，包装有色标的包装材料时，可获得完整的商标图案。进口PID数显式温控，封口温度偏差 $\pm 2^{\circ}\text{C}$ 。PLC控制，可在触摸屏控制面板上轻松设定、调整包装参数。直观显示生产信息，并具有故障自报警、自停机、自诊断的功能，使用安全简单，维护方便。

The automatic packaging machine can automatically complete the multi column automatic quantitative measurement, automatic filling, automatic bag making, sealing, cutting, printing production date and other functions. The servo motor drives the heat sealing film, stable and reliable, high precision. High sensitivity automatic electric eye tracking positioning printing cursor, packaging materials packaging color, can obtain the complete logo. Imported PID digital display temperature control, sealing temperature deviation $\pm 2^{\circ}\text{C}$. PLC control, can be easily set on the touch screen control panel, adjust the packaging parameters. Visual display of production information, and fault alarm, self stop, self diagnosis function, safe and easy to use, easy maintenance.

技术参数 | Technical Parameter

| 型号 Model | 袋宽 Pouch Width | 袋长 Pouch Length | 包装容量范围 Filling Capacity | 包装速度 Packaging Capacity | 重量 Weight | 膜宽 Film width | 列数 Lanes No. | 生产能力 Speed(Bag/min) | 设备尺寸 Machine Dimensions(L*W*H) |
|-------------|-------------------|--------------------|----------------------------|----------------------------|--------------|------------------|-----------------|------------------------|-----------------------------------|
| BVS-220 | 20-70mm | 50-180mm | 100ml | 25-40ppm | 400kg | 220mm | 1 | 40 | 815 x 1155 x 2285mm |
| BVS 2-220 | 20-45mm | 50-180mm | 100ml | 25-40ppm | 400kg | 220mm | 2 | 80 | 815 x 1155 x 2260mm |



机器视频
machine video



包装流程 | Packing Process

| | |
|----------|-----------------------------------|
| 日期打印 | Date code printer |
| 平口切断和易撕口 | Straight line cut with easy tear |
| 倒圆角功能 | Piston pump (for liquid or cream) |
| 异型封口功能 | Round corner function |
| | Shape sealig function |

可选充填装置 | Optional Filling Device

| | |
|-----------|------------------------------------|
| 螺杆粉剂头(粉剂) | Servo Auger Filler(for powder) |
| 量杯颗粒头(颗粒) | Volumetric cup filler(for granule) |
| 活塞泵(膏体) | Piston pump(for liquid or cream) |

- ★不同的物料和不同的下料容积可能会使包装速度有所偏差。
- ★Different products and packing volume will cause speed variation.

产品细节 | Product details



自动膜纠偏装置 Auto Film-aligning System

自动纠正薄膜在运行过程中的偏差，防止袋子再封口后出现错边与对不齐问题。
Automatically align film position during machine operation, avoid the problem of pouch sealing misalignment.

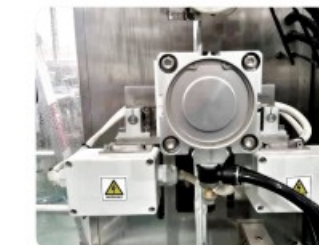

伺服牵袋系统 Servo Pouch-Pulling System

数字化规格切换，简单方便；牵袋更稳定，偏差更小；牵袋扭矩大，胜任高负荷运行。
Easy computerized specification change over, stable pouch pulling with less deviation, large torque moment qualified for full-load running.



集成核心控制系统 Integrated Core Control System

PLC、触摸屏、伺服与气动系统构成高度集成化驱动与控制系统，最大化提高控制精度与可靠性。
PLC, Touch screen, Servo and Pneumatic system compose the drive and control system with higher integration, accuracy and reliability.

产品应用 | Product Application

BVS 系列根据速度及袋子宽度有1列、2列可选。

BVS Series is available in 1 lane and 2 lanes, depending on speed and bag width.

| | | |
|-----------|------------|--------------|
| 粉末/Powder | 颗粒/Granule | 粘稠/Viscosity |
| 固体/Solid | 液体/Liquid | 片剂/Tablet |



立式包装机 Vertical Packager

粉体条状包多列包装机 Multilane Stick Bag Packing Machine For Powder

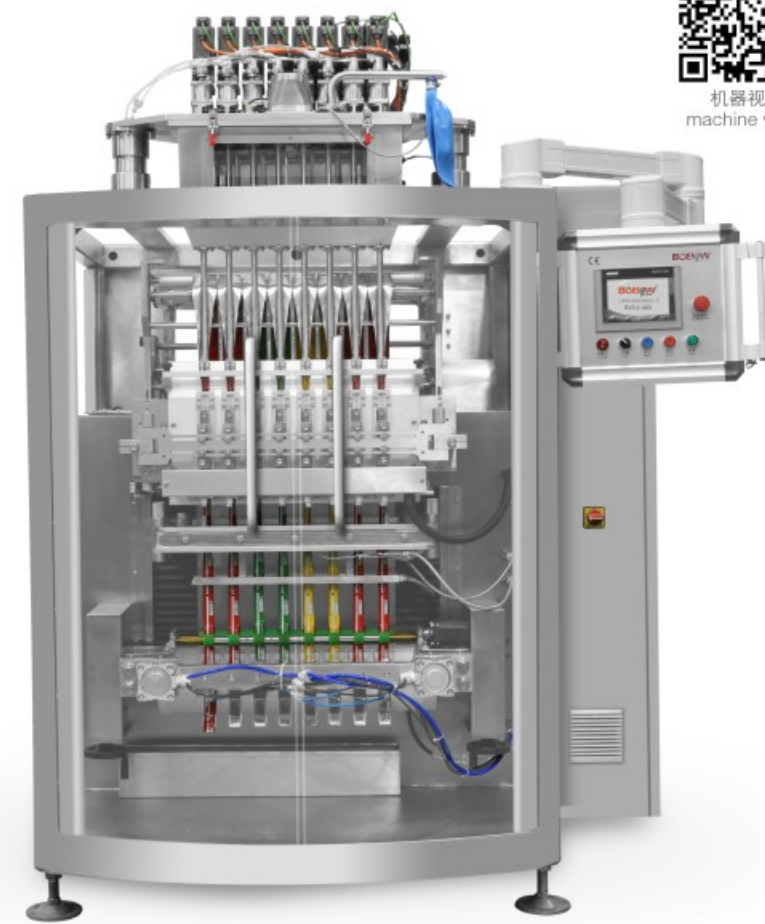

机器视频
machine video

设备特点 | Equipment Characteristics

本自动包装机可自动完成产品多列自动定量计量、自动充填，自动制袋，封口，切断、打印生产日期等功能。
采用伺服牵膜，运行稳定，精准度高。
高灵敏度电眼可自动追踪定位印刷光标，包装有色标的包装材料时，可获得完整的商标图案。
PLC控制，可在触摸屏控制面板上轻松设定、调整包装参数。直观显示生产信息，并具有故障自报警、自停机、自诊断的功能，使用安全简单，维护方便。

The automatic packaging machine can automatically complete the multi column automatic quantitative measurement, automatic filling, automatic bag making, sealing, cutting, printing production date and other functions.
Running with servo pulling system, more stable, higher accuracy.
High sensitivity automatic electric eye tracking positioning printing cursor, packaging materials packaging color, can obtain the complete logo.
PLC control, can be easily set on the touch screen control panel, adjust the packaging parameters. Visual display of production information, and fault alarm, self stop, self diagnosis function, safe and easy to use, easy maintenance.

技术参数 | Technical Parameter

| 型号 Model | 袋长 Pouch length | 袋宽 Pouch Width | 包装速度 Packaging Capacity | 膜宽 Film width | 列数 Lanes No | 重量 Weight | 设备尺寸 Machine Dimensions(L*W*H) |
|-------------|--------------------|-------------------|----------------------------|------------------|----------------|--------------|-----------------------------------|
| BVS 4-480 | 50-180 | 17-50 | 160 | 480mm | 4 | 1800 | 1530 x 1880 x 2700mm |
| BVS 6-480 | 50-180 | 17-30 | 240 | 480mm | 6 | 1900 | 1530 x 1880 x 2700mm |
| BVS 6-680 | 50-180 | 17-45 | 240 | 680mm | 6 | 2000 | 1730 x 1880 x 2700mm |
| BVS 8-680 | 50-180 | 17-30 | 320 | 680mm | 8 | 2100 | 1730 x 1880 x 2700mm |

备注：根据实际袋宽和速度需求，可选择4-12列
Remark: According to the real bag width and speed needs, can provide 4-12 lanes machine model

39 Web: www.boevan.com



多列机包装解决方案 Solution For Multilanes Stick Bag Packing Machine

多列式包装机与伺服螺杆下料装置组合。
采用伺服电机驱动下料螺旋旋转下料，通过控制伺服电机的脉冲数控制下料螺杆转数，与多列式包装机的组合，适用生产粉体类、细颗粒类物料的条状包装产品。
Multilanes powder stick bag packing machine work with servo motor auger filler device
Adopt servo motor to drive screw for filling. Control the number of screw rotations by controlling the number of pulses of the servo motor; suitable for powder, small granule product filling.

选配装置 | Optional Device

日期打印 Date code printer
平口切断和易撕口 Straight line cut with easy tear shape function
异形功能

- ★不同的物料和不同的下料容积可能会使包装速度有所偏差。
- ★ Different products and packing volume will cause speed variation.

产品细节 | Product details

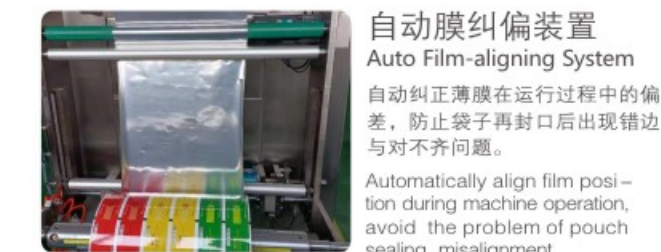

自动膜纠偏装置 Auto Film-aligning System

自动纠正薄膜在运行过程中的偏差，防止袋子再封口后出现错边与对不齐问题。
Automatically align film position during machine operation, avoid the problem of pouch sealing misalignment.



伺服牵袋系统 Servo Pouch-Pulling System

数字化规格切换，简单方便；牵袋更稳定，偏差更小；牵袋扭矩大，胜任高负荷运行。
Easy computerized specification change over, stable pouch pulling with less deviation, large torque moment qualified for full-load running.



多列下料 Multi-lane Filling

多列同时下料，极大提高包装速度；计量精确，偏差小。
Multi-lane filling make huge improvement to packaging speed and capacity, accurate filling, less deviation.

产品应用 | Product Application

BVS系列全自动多列条包设备，根据实际袋宽和速度要求，可选择1-12列主机

BVS Series automatic multilanes stick bag packing machine is available in 1-12 lanes, depending on actual speed and bag width.

粉末/Powder 颗粒/Granule 粘稠/Viscosity
固体/Solid 液体/Liquid 片剂/Tablet



E-mail: info@boevan.cn 40

立式包装机 Vertical Packager

颗粒条状包多列包装机 Multilane Stick Bag Packing Machine For Granule



机器视频
machine video

设备特点 | Equipment Characteristics

本自动包装机可自动完成产品多列自动定量计量、自动充填，自动制袋，封口，切断、打印生产日期等功能。
采用伺服牵膜，运行稳定，精确度高
高灵敏度电眼可自动追踪定位印刷光标，包装有色标的包装材料时，可获得完整的高标图案。
PLC控制，可在触摸屏控制面板上轻松设定、调整包装参数。直观显示生产信息，并具有故障自报警、自停机、自诊断的功能，使用安全简单，维护方便。

The automatic packaging machine can automatically complete the multi column automatic quantitative measurement, automatic filling, automatic bag making, sealing, cutting, printing production date and other functions.

Running with servo pulling system, more stable, higher accuracy
High sensitivity automatic electric eye tracking positioning printing cursor, packaging materials packaging color, can obtain the complete logo.
PLC control, can be easily set on the touch screen control panel, adjust the packaging parameters. Visual display of production information, and fault alarm, self stop, self diagnosis function, safe and easy to use, easy maintenance.

技术参数 | Technical Parameter

| 型号 Model | 袋长 Pouch length | 袋宽 Pouch Width | 包装速度 Packaging Capacity | 膜宽 Film width | 列数 Lanes No | 重量 Weight | 设备尺寸 Machine Dimensions(L*W*H) |
|-------------|--------------------|-------------------|----------------------------|------------------|----------------|--------------|-----------------------------------|
| BVS 4-480 | 50-180 | 17-50 | 160 | 480mm | 4 | 1800 | 1530 × 1880 × 2700mm |
| BVS 6-480 | 50-180 | 17-30 | 240 | 480mm | 6 | 1900 | 1530 × 1880 × 2700mm |
| BVS 6-680 | 50-180 | 17-45 | 240 | 680mm | 6 | 2000 | 1730 × 1880 × 2700mm |
| BVS 8-680 | 50-180 | 17-30 | 320 | 680mm | 8 | 2100 | 1730 × 1880 × 2700mm |

备注：根据实际袋宽和速度需求，可选择4-12列
Remark: According to the real bag width and speed needs, can provide 4-12 lanes machine model

41 Web: www.boevan.com



多列机包装解决方案 Solution For Multilanes Stick Bag Packing Machine

多列式包装机与量杯式下料装置组合。
通过电机驱动旋转量杯，完成物料的自动计量、充填。与多列式包装机的组合，适用生产颗粒类物料的条状包装产品。
Multi-lanes stick bag packing machine running with volumetric cup filler, Complete automatic measurement and filling, it's suitable for small granule product

选配装置 | Optional Device

日期打印 Date code printer
平口切断和易撕口 Straight line cut with easy tear shape function
异形功能

- ★不同的物料和不同的下料容积可能会使包装速度有所偏差。
- ★Different products and packing volume will cause speed variation.

产品细节 | Product details

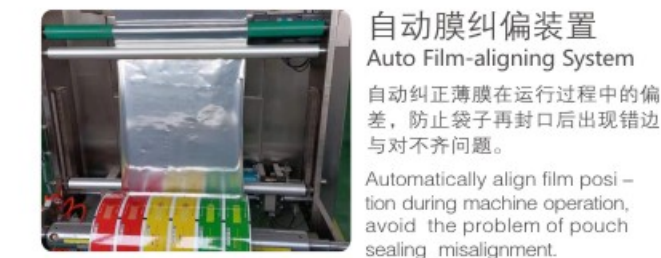

自动膜纠偏装置
Auto Film-aligning System
自动纠正薄膜在运行过程中的偏差，防止袋子再封口后出现错边与对不齐问题。
Automatically align film position during machine operation, avoid the problem of pouch sealing misalignment.



伺服牵袋系统
Servo Pouch-Pulling System
数字化规格切换，简单方便；牵袋更稳定，偏差更小；牵袋扭矩大，胜任高负荷运行。
Easy computerized specification change over, stable pouch pulling with less deviation, large torque moment, qualified for full-load running.

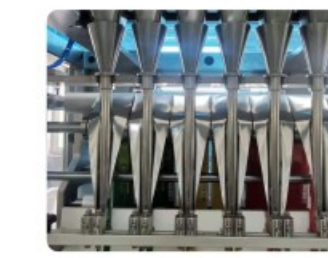

多列下料
Multi-lane Filling
多列同时下料，极大提高包装速度；计量精确，偏差小。
Multi-lane filling make huge improvement to packaging speed and capacity, accurate filling, less deviation.

产品应用 | Product Application

BVS系列全自动多列条包设备，根据实际袋宽和速度要求，可选择1-12列主机
BVS Series automatic multilanes stick bag packing machine is available in 1-12 lanes, depending on actual speed and bag width.

粉末/Powder 颗粒/Granule 粘稠/Viscosity
固体/Solid 液体/Liquid 片剂/Tablet



E-mail: info@boevan.cn 42

立式包装机 Vertical Packager

液体条状包多列包装机 Multilane Stick Bag Packing Machine For Liquid



机器视频
machine video



设备特点 | Equipment Characteristics

本自动包装机可自动完成产品多列自动定量计量、自动充填，自动制袋，封口，切断、打印生产日期等功能。
采用伺服牵膜，运行稳定，精确度高。
高灵敏度电眼可自动追踪定位印刷光标，包装有色标的包装材料时，可获得完整的商标图案。
PLC控制，可在触摸屏控制面板上轻松设定、调整包装参数。直观显示生产信息，并具有故障自报警、自停机、自诊断的功能，使用安全简单，维护方便。

The automatic packaging machine can automatically complete the multi column automatic quantitative measurement, automatic filling, automatic bag making, sealing, cutting, printing production date and other functions.

Running with servo pulling system, more stable, higher accuracy.
High sensitivity automatic electric eye tracking positioning printing cursor, packaging materials packaging color, can obtain the complete logo.

PLC control, can be easily set on the touch screen control panel, adjust the packaging parameters. Visual display of production information, and fault alarm, self stop, self diagnosis function, safe and easy to use, easy maintenance.

技术参数 | Technical Parameter

| 型号 Model | 袋长 Pouch length | 袋宽 Pouch Width | 包装速度 Packaging Capacity | 膜宽 Film width | 列数 Lanes No | 重量 Weight | 设备尺寸 Machine Dimensions(L*W*H) |
|-------------|--------------------|-------------------|----------------------------|------------------|----------------|--------------|-----------------------------------|
| BVS 4-480 | 50-180 | 17-50 | 160 | 480mm | 4 | 1800 | 1530 × 1880 × 2700mm |
| BVS 6-480 | 50-180 | 17-30 | 240 | 480mm | 6 | 1900 | 1530 × 1880 × 2700mm |
| BVS 6-680 | 50-180 | 17-45 | 240 | 680mm | 6 | 2000 | 1730 × 1880 × 2700mm |
| BVS 8-680 | 50-180 | 17-30 | 320 | 680mm | 8 | 2100 | 1730 × 1880 × 2700mm |

备注：根据实际袋宽和速度需求，可选择4-12列
Remark: According to the real bag width and speed needs, can provide 4-12 lanes machine model



多列机包装解决方案 Solution For Multilanes Stick Bag Packing Machine

多列式包装机与活塞式下料装置组合。
利用气缸推动活塞往复运动，带动单向阀开闭，并通过调整活塞的行程来控制送料流量。与多列式包装机的组合，适生产液体类物料的条状包装产品。
Multilanes stick bag packing machine running with piston pump filler device.
Use the cylinder to move the piston Varves, Drive the one-way valve to open and close. Control the filling weight by adjusting the stroke of the piston suitable for liquid product.

选配装置 | Optional Device

日期打印 Date code printer
平口切断和易撕口 Straight line cut with easy tear shape function
异形功能

- ★不同的物料和不同的下料容积可能会使包装速度有所偏差。
- ★Different products and packing volume will cause speed variation.

产品细节 | Product details

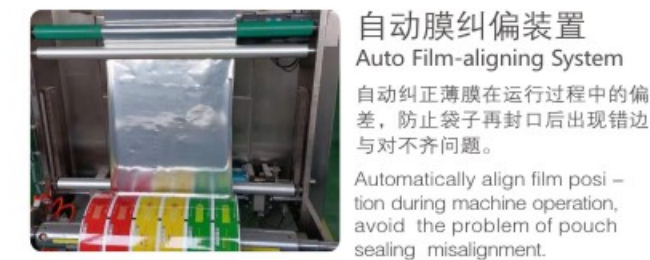

自动膜纠偏装置
Auto Film-aligning System
自动纠正薄膜在运行过程中的偏差，防止袋子再封口后出现错边与对不齐问题。
Automatically align film position during machine operation, avoid the problem of pouch sealing misalignment.



伺服牵袋系统
Servo Pouch-Pulling System
数字化规格切换，简单方便；牵袋更稳定，偏差更小；牵袋扭矩大，胜任高负荷运行。
Easy computerized specification change over, stable pouch pulling with less deviation, large torque moment qualified for full-load running.

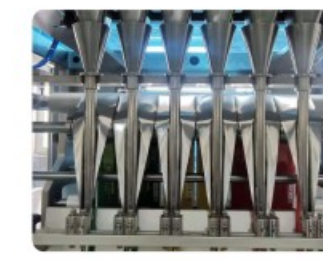

多列下料
Multi-lane Filling
多列同时下料，极大提高包装速度；计量精确，偏差小。
Multi-lane filling make huge improvement to packaging speed and capacity, accurate filling, less deviation.

产品应用 | Product Application

BVS系列全自动多列条包设备，根据实际袋宽和速度要求，可选择1-12列主机。
BVS Series automatic multilanes stick bag packing machine is available in 1-12 lanes, depending on actual speed and bag width.

粉末/Powder 颗粒/Granule 粘稠/Viscosity
固体/Solid 液体/Liquid 片剂/Tablet



立式包装机 Vertical Packager



全自动四边封多列包装机 Automatic Four-side Sealing & Multi-Line Packing Machine



机器视频
machine video



设备特点 | Equipment Characteristics

生产线由PLC控制, 操作简易, 采用全光谱光电检测装置, 定位精准, 运行稳定, 生产线集中控制, 自动化程度高, 节约人工成本, 伺服驱动, 运行平稳可靠。

PLC control, easy to operate. Full-spectrum photocell, accurate positioning and stable operation. Integrated control, high automation, save labor costs. Servo driven, stable and reliable operation.

技术参数 | Technical Parameter

| 型号 Model | 袋长 Pouch Length | 袋宽 Pouch Width | 膜宽 Film Length(mm) | 列数 Lanes No. | 生产能力 Speed(Bag/Min) | 封口方式 Sealing Format |
|-------------|--------------------|-------------------|-----------------------|-----------------|------------------------|------------------------------------|
| BVS-500F | 50-300 | 32-105 | 500 | 7 | 280-420 | 背封或贴封 Fin Seal or Envelope Seal |
| BVS-900F | 50-300 | 32-105 | 900 | 14 | 560-840 | 背封或贴封 Fin Seal or Envelope Seal |
| BVS-1200F | 50-120 | 40-105 | 1200 | 15 | 600-900 | 背封或贴封 Fin Seal or Envelope Seal |

45 Web: www.boevan.com



BVS 系列多列机专门为Stick袋而设计, 有 1,4,6,8列可选
BVS Series Multi-lane packager designed for stick, available in 1, 4, 6, 8 lanes

选配装置 | Optional Device

| | |
|----------|---|
| 日期打印 | Date code printer |
| 平口切断和易撕口 | Straight line cut with easy tear shape function |
| 异形功能 | |

可选充填装置 | Optional Filling Device

| | |
|-----------|------------------------------------|
| 螺杆粉剂头(粉剂) | Servo Auger Filler(for powder) |
| 量杯颗粒头(颗粒) | Volumetric cup filler(for granule) |
| 电子泵(液体) | Electrical gear pump(for liquid) |

- ★不同的物料和不同的下料容积可能会使包装速度有所偏差。
- ★Different products and packing volume will cause speed variation.

产品细节 | Product details



自动膜纠偏装置 Auto Film-aligning System

自动纠正薄膜在运行过程中的偏差, 防止袋子再封口后出现错边与对不齐问题。
Automatically align film position during machine operation, avoid the problem of pouch sealing misalignment.



伺服牵袋系统 Servo Pouch-Pulling System

数字化规格切换, 简单方便; 牵袋更稳定, 偏差更小; 牵袋扭矩大, 胜任高负荷运行。
Easy computerized specification change over, stable pouch pulling with less deviation, large torque moment, qualified for full-load running.



多列下料 Multi-lane Filling

多列同时下料, 极大提高包装速度; 计量精确, 偏差小。
Multi-lane filling make huge improvement to packaging speed and capacity, accurate filling, less deviation.

产品应用 | Product Application

BVS系列专为平袋需求而设计, 灌装灵活, 主要应用于粉末, 颗粒, 液体。

BVS Series designed for flat bag, with flexible filling functions, suitable for: powder, granule, liquid and so on.

| | | |
|-----------|------------|--------------|
| 粉末/Powder | 颗粒/Granule | 粘稠/Viscosity |
| 固体/Solid | 液体/Liquid | 片剂/Tablet |



E-mail: info@boevan.cn 46

立式包装机 Vertical Packager

BVL-420/520/620/720



机器视频
machine video

设备特点 | Equipment Characteristics

集成核心控制，可在线调节袋宽、袋高、装量等数据，简单易操作采用伺服牵膜系统，运行稳定可靠，避免膜错边现象

Integrated control, Simple adjust bag size and volum on HMI, easy to operate.Servo film pulling system, stable and reliable operation, to avoid film misaligning.

技术参数 | Technical Parameter

| 型号 Model | 袋型尺寸范围 Pouch Size | 包装速度 Packaging Capacity | | 功率与压缩空气用量 Powder & Air Consumption | 重量 Weight | 外型尺寸 Machine Dimensions |
|-------------|----------------------------|-------------------------|-------------------------|---------------------------------------|--------------|----------------------------|
| | | 标准机械 Standard Mode | 高速机械 High-speed Mode | | | |
| BVL-420 | W 80-200mm H 80-300mm | 25-60PPM | Max.90PPM | 3.0KW 6-8kg/m ² | 500kg | L1650 x W1300 x H1700mm |
| BVL-520 | W 80-250mm H 100-350mm | 25-60PPM | Max.90PPM | 5.0KW 6-8kg/m ² | 700kg | L1350 x W1800 x H1700mm |
| BVL-620 | W 100-300mm H 100-400mm | 25-60PPM | Max.90PPM | 4.0KW 6-10kg/m ² | 800kg | L1350 x W1800 x H1700mm |
| BVL-720 | W 100-350mm H 100-450mm | 25-60PPM | Max.90PPM | 3.0KW 6-8kg/m ² | 900kg | L1650 x W1800 x H1700mm |

47 Web:www.boevan.com



选配装置 | Optional Device

- 充气装置
Air Flushing System
- 冲氮装置
Nitrogen Gas Flushing System
- 插角装置
Gusset Device
- 排气装置
Air Expeller
- 冲孔装置
Hole Punching Device
- 振料装置
Flip Device
- 易撕口装置
Tear Notch Device
- 防夹料装置
Material Clamping Proof Device
- 除静电装置
Static Charge Eliminator
- 压线装置（四边）
4-Line Folding Device
- 薄膜自动纠偏装置
Film Tracking Device

- ★不同的物料和不同的下料容积可能会使包装速度有所偏差。
- ★Different products and packing volume will cause speed variation.

产品细节 | Product details



集成核心控制系统
Integrated Core Control System
PLC, 触摸屏, 伺服与气动系统构成高度集成化驱动与控制系统, 最大化提高控制精度与可靠性。
PLC, Touch screen, Servo and Pneumatic system compose the drive and control system with higher integration, accuracy and reliability.



灵活的横封封口装置
Flexible Horizontal Sealing System
封口压力与行程轻易调整, 能满足各种包材与袋型, 封口强度高避免破包漏气。
Easy to adjust sealing pressure and open travel, suitable for various packaging material and bag type, high sealing strength without leakage.



伺服牵膜系统
Servo Pulling System
袋长更精准, 牵膜更平整, 摩擦小并且运行噪音更低。
Higher accuracy in bag length, more smooth in film pulling, lower friction and operation noise.

产品应用 | Product Application

BVL-420/520/620/720 大袋立式包装机可以实现背封和插脚背封的全自动包装需求。

BVL-420/520 /620/720 Large vertical packager can make pillow bag and gusset pillow bag.

粉末/Powder 颗粒/Granule 粘稠/Viscosity
固体/Solid 液体/Liquid 片剂/Tablet

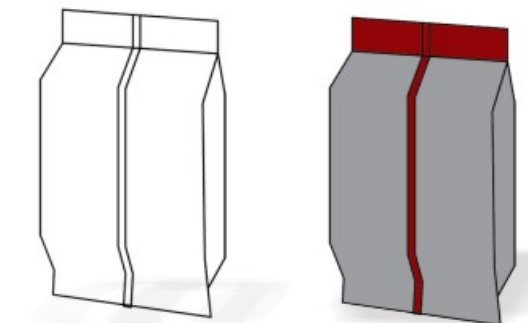

E-mail: info@boevan.cn 48

立式包装机 Vertical Packager

BVL-520Q



设备特点 | Equipment Characteristics

集成核心控制，可在线调节袋宽、袋高、装量等数据，简单易操作采用伺服牵膜系统，运行稳定可靠，避免膜错边现象

Integrated control, Simple adjust bag size and volum on HMI, easy to operate. Servo film pulling system, stable and reliable operation, to avoid film misaligning.

技术参数 | Technical Parameter

| 型号 Model | 袋型尺寸范围 Pouch Size | 包装速度 Packaging Capacity | 重量 Weight | 外型尺寸 Machine Dimensions |
|-------------|---|----------------------------|--------------|-----------------------------------|
| BVL-520Q | Pouch Width: 80mm-250mm Front Width: 80mm-180mm Side Width: 40-90mm Pouch Length 100mm-350mm | 25-60PPM | 750kg | L1350mm x W1800mm x H2000mm |



选配装置 | Optional Device

- 充气装置
Air Flushing System
- 冲氮装置
Nitrogen Gas Flushing System
- 排气装置
Air Expeller
- 冲孔装置
Hole Punching Device
- 振料装置
Flip Device
- 防夹料装置
Material Clamping Proof Device
- 除静电装置
Static Charge Eliminator
- 薄膜自动纠偏装置
Film Tracking Device

- ★不同的物料和不同的下料容积可能会使包装速度有所偏差。
- ★Different products and packing volume will cause speed variation.

产品细节 | Product details



集成核心控制系统
Integrated Core Control System
PLC, 触摸屏, 伺服与气动系统构成高度集成化驱动与控制系统, 最大化提高控制精度与可靠性。
PLC, Touch screen, Servo and Pneumatic system compose the drive and control system with higher integration, accuracy and reliability.



灵活的横封封口装置
Flexible Horizontal Sealing System
封口压力与行程轻易调整, 能满足各种包材与袋型, 封口强度高避免破包漏气。
Easy to adjust sealing pressure and bag length, suitable for various packaging material and bag type, high sealing strength without leakage.

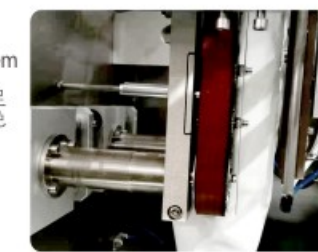

伺服牵膜系统
Servo Pulling Sytem
袋长更精准, 牵膜更平整, 摩擦小并且运行噪音更低。
Higher accuracy in bag length, more smooth in film pulling, lower friction and operation noise.

产品应用 | Product Application

BVL-520Q 大袋立式包装机可以实现四角封盒式袋的全自动包装需求, 运行稳定, 包装精美。

BVL-520Q Large vertical packager can make Quad-seal box bag, smooth running, nice packing.

粉末/Powder 颗粒/Granule 粘稠/Viscosity
固体/Solid 液体/Liquid 片剂/Tablet



全自动装盒机械 Automatic Cartoner



BCP-120G/K

产品广泛应用于制药行业针剂型产品的自动装盒,使用于化妆品、日用品、药品(铝塑板、软管、药瓶)食品、电子照明及软袋装盒等以及相似物品的开盖装盒,对彩盒尺寸适应范围大,更换品种调节方便。

They are widely used for automatic packing of injection products in pharmaceutical industry. They are used for packing of cosmetics, daily necessities, drugs (aluminum-Plastic, plate, tube and bottle) food and electronic lighting, soft bag automatic cartoner similar articles, colorful boxes of wide range can be packed and adjustment is convenient.



机器视频
machine video

BCP-120G/K 软膏/针剂型自动装盒机
BCP-120G/K Automatic Cartoner for ointment or injection



工作基本原理 | Basic Principle

本机器采用一系列复杂的传动,模仿人的动作来自动完成下盒、开盒、折叠说明书、装物料、装说明书及封盒等工序的。

The machine uses a series of complex transmission, imitate the action of people to automatically complete the box, open the box, folding instructions, loading materials, packing instructions and sealing procedures.



工作基本流程图 | Basic Flow Chart

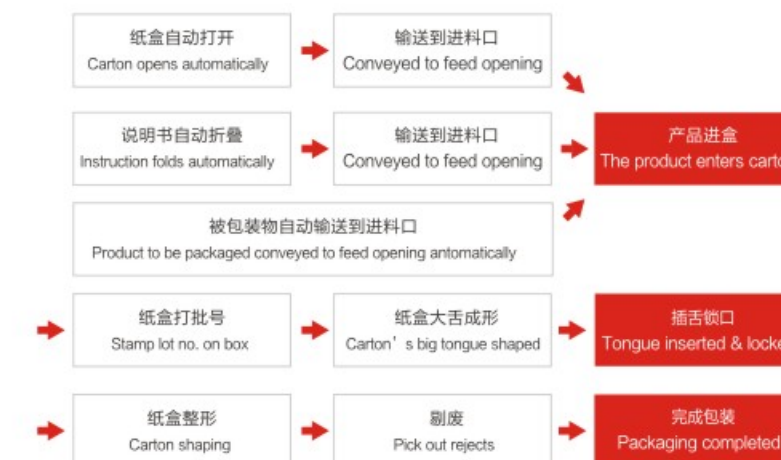

技术参数 | Technical Parameter

| 名称 Name | 单位 Unit | 数值和说明 Specifications/Description | | 备注 Note |
|-------------------------------------|------------|--|--|------------|
| 机型 | / | BCP-120G | BCP-120K | |
| 整体外形尺寸 Overall dimensions | mm | 2600*1000*1550 | 2600*1000*1550 | |
| 装盒机总功率 Carton total power | kw | 1.2 | 1.5 | |
| 工作电压 Working voltage | v | 380 | 380 | |
| 装盒速度 Packing speed | Box/min | 60-100 box/min (stable speed) | 70-120 box/min (stable speed) | |
| 纸盒规格 Carton specifications | L*W*H | (120-170)* (84-130)*(30-60) | (150-230)* (130-175)*(30-60) | |
| 纸盒纸质 Carton paper | g | 250-230(white card) or 300-350(gray board) | 250-230(white card) or 300-350(gray board) | |
| 启动电流 Starting current | A | 10 | 10 | |
| 满载运转电流 Full-load running current | A | 5 | 5 | |
| 耗气量 Gas consumption | L/min | 5-20 | 5-20 | |
| 压缩空气 Compress air | Mpa | 0.5-0.8 | 0.5-0.8 | |
| 真空抽气量 Vacuum pumping | L/min | 20 | 20 | |
| 真空度 Degree of vacuum | Mpa | -0.08 | -0.08 | |
| 总质量 Total weight | kg | 900 | 1050 | |
| 噪声 Noise | ≤dB | 70 | 70 | |

生产流程示意图 Production Flow Diagram

全自动装箱装箱整线方案 Full Automatic Packing Line Solution

食品 Food 化妆 Cosmetics 化工 Chemical 饮料 Beverages 制药 Pharma



机器视频
machine video

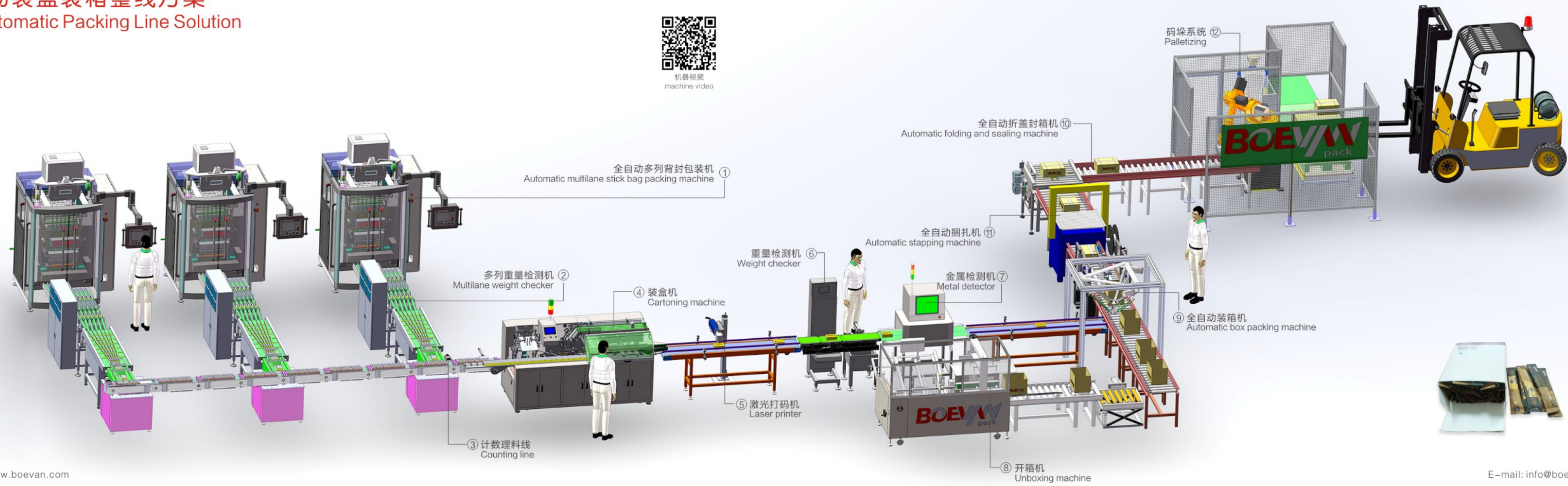

生产流程示意图
Production Flow Diagram

生产流程示意图
Production Flow Diagram

下料装置 Filling Devices

多头组合秤 Multi-head Combination Weigher

适用于膨化食品, 坚果, 休闲、冷冻食品, 糖果等各种颗粒状、块状、球状物料的定量称重下料。

Multi-head Combination Weigher is an ideal solution for quantitative weighing and filling of puffed food, nuts, leisure or frozen food, candy etc.. With various product shapes like granule, block or conglobation.



技术参数 | Technical Parameter

| 型号 Model | FW-10 | FW-14 | FW-18 | FW-20 |
|-----------------------|----------------|----------------|----------------|----------------|
| 描述 Description | 10头 10-head | 14头 14-head | 18头 18-head | 20头 20-head |
| 下料容积 Filling Capacity | 10-3000g | 10-3000g | 10-1000g | 10-1000g |
| 下料精度 Filling Accuracy | ±0.1-2g | ±0.1-2g | ±0.1-2g | ±0.1-2g |

功能特点 | features

全新高集成模块控制系统
振幅自动调整功能, 调试更方便
可以同时称量多种不同物料, 实现混合物料包装
根据生产情况可在运行中直接修改参数, 操作简便
采用无级振机加料系统, 使物料更均匀, 称重范围更大

采用高精度、高标准的特制传感器
智能化的多次采样稳定模式, 称量更精准
智能化的故障报警提示, 维修更方便
高速异步放料功能, 有效防止物料阻塞
全新高集成模块化设计, 采用CAN总线技术
Modbus工业标准通信协议, 实现组合秤和包装机界面合二为一

Grand new modular control system
Adopt stepless vibrating feeding system to make products flow more fluently
Make mix different products weighing at one discharge
Parameter can be freely adjusted according to production

High accuracy and tailored load cell
Intelligent multi-sampling stable mode, higher accuracy
Intelligent alarm diagnosis
High speed stagger dump function
Modular and CAN bus technology, more efficient and stable
Modbus industry communication protocol



伺服螺杆 Servo Motor Auger Filler

采用伺服电机驱动下料螺杆旋转下料, 通过控制伺服电机的脉冲数控制下料螺杆转速, 性能稳定可靠, 调节简单快捷。适用于粉体类、细颗粒类物料的下料。

Auger Filler driven by servo motor with feature of stable, reliable and easy adjustment; suitable for powder, granule product filling.

应用范围 | Product Application

粉剂类: 调味品, 奶粉, 葡萄糖, 洗衣粉, 化学原料, 精细白糖, 农药, 肥料等。
细颗粒类: 砂糖, 鸡精, 种子等。

Powder: Seasoning, Milk Powder, Glucose Powder, Detergent Powder, Chemical Powder, Fine Sugar, Agrichemical Powder, Fertilizer, Etc.
Granule: Granulated Sugar, Chicken Essence Granule, Seed, Etc.



| 型号 Model | FA-1 | FA-1-L | FA-2 | FA-3 | FA-4 |
|-----------------------|-----------------------------|-----------------------------|---------------------|----------------------|------------------------|
| 描述 Description | 小型单出模式 Small Single Mode | 大型单出模式 Large Single Mode | 双出模式 Duplex Mode | 三出模式 Triplex Mode | 四出模式 Quadruple Mode |
| 下料容积 Filling Capacity | 2-250 ml | 5-1000 ml | 2-250 ml | 2-250 ml | 2-250 ml |
| 下料精度 Filling Accuracy | ±0.3-1.2% | ±0.3-1.2% | ±0.3-1.2% | ±0.3-1.2% | ±0.3-1.2% |



量杯下料 Volumetric Cup Filling Device

通过电机驱动旋转量杯, 完成物料的自动计量、充填。
适用于颗粒类物料。

Volumetric Cup Filler can do automatic measurement and filling. Suitable for granule product filling.

应用范围 | Product Application

粉剂类: 调味品, 奶粉, 葡萄糖, 洗衣粉, 化学原料, 精细白糖, 农药, 肥料等。
颗粒类: 砂糖, 鸡精, 种子等。

Powder: Seasoning, Milk Powder, Glucose Powder, Detergent Powder, Chemical Powder, Fine Sugar, Agrichemical Powder, Fertilizer, Etc.
Granule: Granulated Sugar, Chicken Essence Granule, Seed, Etc.

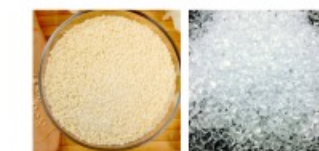

| 型号 Model | FV-3L | FV-4L | FV-6S | FV-6L |
|-----------------------|-------------------------------|---------------------------------|-----------------------------|-----------------------------|
| 描述 Description | 三出线性模式 Triplex Linear Mode | 四出线性模式 Quadruple Linear Mode | 小型旋转模式 Small Rotary Mode | 大型旋转模式 Large Rotary Mode |
| 下料容积 Filling Capacity | 2-150 ml | 2-150 ml | 5-135 ml | 50-500 ml |
| 下料精度 Filling Accuracy | ±0.3-1.2% | ±0.3-1.2% | ±0.3-1.2% | ±0.3-1.2% |

下料装置 Filling Devices

多头线性秤 Multiple linear balance

可与封口输送设备组成小型包装生产线。与物料接触部分都可方便拆洗,可中/英文界面操作,具有设计先进,性能可靠,操作简单,运转平稳,噪声音小,易维修,耐腐蚀等特点。

Can be composed small packaging production line with the sealing and conveying equipment. Simple and safe operation, one machine has greatly increased the production efficiency. Parts contacting with materials are easy to unpick and wash. Can switch operating in both English and Chinese, with advanced design, reliable performance, simple operation, stable operation, low noise, easy maintenance, corrosion resistance, etc.



应用范围 | Product Application

各类食品、调味品、咖啡制品、宠物饲料、奶粉、种子、各类粮食、医药化工,日用化工(洗衣粉)等颗粒状物料及粉料的小剂量定量包装。

Applicable scope: all kinds of food, spices, coffee products, pet food, milk powder, seeds, all kinds of food, medical chemical industry, daily chemical (washing powder) and other granular material and powder of small dose of quantitative packaging.



| 型号 Model | 称量范围 Weighing range | 称量速度 Weighing speed | 用电功率 Power consumption | 电压 Voltage |
|-------------|--------------------------|--------------------------------|---------------------------|---------------|
| NE-2000-8 | 100克-1000克 100g-1000g | 25-50包/分钟 25-50Packet / min | 1.5千瓦 1.5KW | 220伏 220V |

57 Web:www.boevan.com

活塞式下料 Piston Filling Device

利用气缸推动活塞往复运动,带动单向阀开闭,并通过调整活塞的行程来控制送料流量。结合气动控制系列使之自动化工作。适用于粘稠体、胶悬体、乳油等流动性较差的液体物料灌装下料。

Use the cylinder to move the piston Vanves. Drive the one-way valve to open and close. Control the filling weight by adjusting the stroke of the piston. Piston Pump is suitable for liquid product: viscous or colloidal liquid, cream and other non free-flowing liquid.



应用范围 | Product Application

液体类: 牛奶, 果汁, 饮料, 米醋, 酱油, 黄酒, 柔顺剂。
Liquid: Milk, Fruit Juice, Drinks, Rice Vinegar, Soy Sauce, Liquor, Softener, Etc.

黏体类: 番茄酱, 花生酱, 果酱, 辣椒酱, 豆瓣酱, 蜂蜜, 洗洁精, 洗衣液等。
Granule: Tomato Ketchup, Peanut Ketchup, Jam, Chili Sauce, Honey, Detergent, Etc.

| 型号 Model | FP-250 | FP-1000 | FP-250H | FP-1000H |
|--------------------------|-----------------------------|-----------------------------|--|--|
| 描述 Description | 小剂量活塞泵 Small Volume Mode | 大剂量活塞泵 Large Volume Mode | 高粘度小剂量活塞泵 High Viscosity Small Volume Mode | 高粘度大剂量活塞泵 High Viscosity Large Volume Mode |
| 下料容积 Filling Capacity | 5-250 ml | 50-1000 ml | 5-250 ml | 50-1000 ml |
| 下料精度 Filling Accuracy | ±0.5-1.2% | ±0.5-1.2% | ±0.5-1.2% | ±0.5-1.2% |

数粒下料 Tablet Counting Filler

该机采用光电效应原理,通过光电传感器产生的脉冲信号输入到高速 PLC 编程控制器,再通过电路和程序的配合实现计数功能,能保证其数粒准确度。采用独立的光学检测系统,可避免由粉尘造成的影响,从而保证高水准数粒精度和速度。

Through the photoelectric principle, when tablets falling, they are sensed by a photoelectric sensor, and produce pulse signals which will be input to a high-speed PLC controller, and realizes the counting function through the cooperation of the circuit and procedure. Checking system is adopted to avoid dust pollution, ensuring the accuracy and speed of tablet counting.



应用范围 | Product Application

颗粒类: 胶囊, 药片等。
Granule: Capsule, Tablet, Etc.

块状类: 糖果, 红枣, 麦片, 巧克力, 饼干, 花生, 青豆, 冰糖, 日用品, 膨化食品等。
Solid: Candy, Jujube, Oatmeal, Chocolate, Cookie, Peanut, Green soya beans, Crystal sugar, Puffed food, Daily necessities and etc.



| 型号 Model | FC-06/08/10/12/16 |
|------------------------|---|
| 供料轨道 Multi Channels | 可提供 12、16、24、32 等多种不同的供料轨道组合,以适应不同的数粒需求。 Multi-channels 12, 16, 24, 32, is available to fit for any requirements |
| 数粒速度 Counting Speed | 16,000pcs/min |
| 产品尺寸 Product Size | 厚: 3-10 mm, 直径: 3-13 mm, 长: 3-24 mm Thickness: 3-10 mm, 3-13 mm, Length: 3-24 mm |

振动式下料 Vibrate Filler

震动盘是一种自动定向排序的送料设备。其工作目的是通过振动将无序工件自动有序定向排列整齐、准确地输送到下道工序。

Vibrate Filler is an automatic filling device with oriented arrangement. It could sequence, sort, detect and count materials by vibrating, and send the materials to next working procedure.



应用范围 | Product Application

电子类: 晶体管、二三极管、LED、电容
Electronic Component: Transistor, Diode, Triode, LED, Capacitor
塑料类: 瓶盖、吸嘴、呼吸阀
Plastic: Cap, Spout, Valve
五金类: 螺丝、轴承、配件
Hardware: Screw, Bearing, Spare Parts



| 型号 Model | FA-01 |
|----------------------|---|
| 料斗类型 Hopper Type | 筒形料斗、螺旋料斗、线料斗、锥形料斗、等分线料斗 Cylindrical hopper, Spiral Hopper, Linear Hopper, Tapered Hopper, Equational Hopper |
| 功能 Function | 排序、分选、检测、计数 Sequencing, Sorting, Detecting, Counting |
| 产品尺寸 Product Size | 针对不同产品的形状和大小定制 Customized on different shape and size |

E-mail: info@boevan.cn 58

上料装置 Feeding Devices



螺杆输料机
Inclined Screw Feeder



水平螺杆输料机
Horizontal Screw Feeder



Z型斗式提升机
Z Type Bucket Conveyor



真空输料机
Vacuum Feeder

辅助装置 Assisive Devices



重量检测机
Checking Weigher



日期喷码机
Date Printer



粉尘捕集器
Dust Collector



工作平台
Opration Platform



E-mail: info@boevan.cn 60